

GB Light oil burners

One stage operation

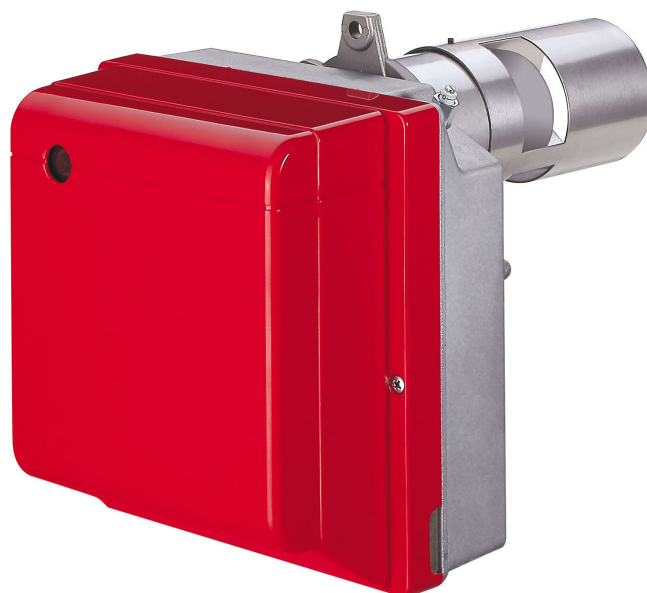

B100

CODE	MODEL
20204457	BGK1 B100
20204458	BGK2 B100
20204459	BGK3 B100



Translation of the original instructions

1	Declaration	3
2	Information and general warnings	4
2.1	Information about the instruction manual	4
2.1.1	Introduction	4
2.1.2	General dangers	4
2.1.3	Other symbols	4
2.1.4	Delivery of the system and the instruction manual	5
2.2	Guarantee and responsibility	5
2.3	Guide to the use of biofuel mixtures	6
2.3.1	Information and general instructions	6
2.3.2	Product liability disclaimer	6
3	Safety and prevention	7
3.1	Introduction	7
3.2	Personnel training	7
4	Technical description of the burner	8
4.1	Burner designation	8
4.2	Models available	8
4.3	Technical data	9
4.4	Electrical data	9
4.5	Burner equipment	9
4.6	Maximum dimensions	10
4.7	Burner description	10
4.8	Firing rate	11
4.8.1	Test boiler	11
4.8.2	Commercial boilers	11
4.9	Electrical control box	12
5	Installation	13
5.1	Notes on safety for the installation	13
5.2	Instructions to avoid burnout or bad combustion of the burner	13
5.3	Handling	13
5.4	Preliminary checks	14
5.5	Installer notes for the use of biofuel	14
5.6	Operating position	15
5.7	Securing the burner to the boiler	16
5.8	Combustion head adjustment	17
5.9	Air damper setting	17
5.10	Electrode adjustment	18
5.11	Optical fiber positioning	18
5.12	Fuel heating	18
5.13	Maintenance position	19
5.14	Hydraulic systems	20
5.14.1	Fuel supply	20
5.14.2	Pump	21
5.14.3	Pressure adjustment	21
5.14.4	Single pipe pressure systems	21
5.14.5	Priming pump	22
5.14.6	Depressurized systems	22
6	Start-up, calibration and operation of the burner	23
6.1	Notes on safety for the first start-up	23
6.2	Combustion adjustment	23
6.3	Nozzles	28

6.4	Electric system	29
6.5	Wiring diagram	30
6.6	Operating programme	31
6.7	Table of times	32
6.7.1	Operation status indication	32
6.7.2	Fault diagnostics - lockouts	33
6.7.3	Fuel pre-heating function	33
6.7.4	Switching off test	33
6.7.5	Intermittent operation	33
6.7.6	Recycle and limit of repetitions	33
6.7.7	Ignition device protection function	34
6.7.8	Presence of an extraneous light or parasite flame	34
6.7.9	Pre-ignition phase of ignition transformer spark	34
6.7.10	Integrated reset button and remote burner reset	34
6.7.11	Reset protection function	34
6.7.12	Reset button/remote reset fault	34
6.7.13	External lockout signal (S3)	34
6.7.14	Hour counter function (B4)	34
6.7.15	Monitoring the power supply voltage	35
6.7.16	Frequency supply error	35
6.7.17	Internal voltage anomaly	35
6.7.18	Checking the fan motor	35
6.7.19	Checking the internal electronic control circuit of the 1st stage valve	35
6.7.20	Checking the internal electronic control circuit of the 2nd stage valve(*)	35
6.7.21	Checking the 1st stage valve short circuit	35
6.7.22	EEPROM check	35
6.7.23	Post-purging	35
6.7.24	Continuous purging	36
6.7.25	Lockout log	36
6.7.26	Logging of burner operating parameters	36
6.7.27	Admissible lengths of the external connections to the burner	36
6.7.28	Long pre-purging	36
6.8	Fuel pre-heating automatic deactivation	37
6.9	Programming menu	38
6.9.1	General notes	38
6.9.2	Block diagram for entering the menu	38
6.9.3	Switching off test	39
6.9.4	Post-purging and continuous purging	39
6.9.5	Intermittent operation	39
6.9.6	Setting the 2nd stage opening delay	39
6.9.7	Setting a long pre-purging	39
6.9.8	Displaying the lockout log	39
6.9.9	Resetting the programming menu parameters and the lockout log	39
6.10	Lockout types	40
7	Maintenance	41
7.1	Notes on safety for the maintenance	41
7.2	Maintenance programme	41
7.2.1	Maintenance frequency	41
7.2.2	Checking and cleaning	41
8	Faults / Solutions	43
9	Appendix - Accessories	44

1 Declaration**Declaration of Conformity A.R. 8/1/2004 & 17/7/2009 – Belgium**

Manufacturer: RIELLO S.p.A.
37045 Legnago (VR) Italy
Tel. ++39.0442630111
www.riello.com

Distributed by: VAN MARCKE HQ
LAR Blok Z 5,
B-8511 Kortrijk (Aalbeke) Belgium
Tel. +32 56 23 7511
e-mail: riello@vanmarcke.be
URL. www.vanmarcke.com

This document certifies that the series of devices specified below is in compliance with the EC Declaration of Conformity supplied with the burner and has been manufactured and distributed in compliance with the requirements defined in the A.R. of January 8th 2004 and July 17th 2009.

Type of product: Light oil and biodiesel burners

Model: BGK1 B100
BGK2 B100
BGK3 B100

Regulation applied: EN 267 * and A.R. of January 8th 2004 - July 17th 2009

Emissions: CO < 155 mg/kWh
NOx < 120 mg/kWh

* Standard referring to light oil only.

Manufacturer's Declaration

RIELLO S.p.A. declares that the following products comply with the NOx emission limits specified by German standard "1. BImSchV revision 26.01.2010".

Product	Model	Output
Light oil burners	BGK1 B100	17.8 - 35.6 kW
	BGK2 B100	32 - 59.3 kW
	BGK3 B100	45 - 73 kW

2 Information and general warnings

2.1 Information about the instruction manual

2.1.1 Introduction

The instruction manual supplied with the burner:

- is an integral and essential part of the product and must not be separated from it; it must therefore be kept carefully for any necessary consultation and must accompany the burner even if it is transferred to another owner or user, or to another system. If the manual is lost or damaged, another copy must be requested from the Technical Assistance Centre of the area;
- is designed for use by qualified personnel;
- offers important indications and instructions relating to the installation safety, start-up, use and maintenance of the burner.

Symbols used in the manual

In some parts of the manual you will see triangular DANGER signs. Pay great attention to these, as they indicate a situation of potential danger.

2.1.2 General dangers

The **dangers** can be of **3 levels**, as indicated below.



Maximum danger level!
This symbol indicates operations which, if not carried out correctly, cause serious injury, death or long-term health risks.



This symbol indicates operations which, if not carried out correctly, may cause serious injury, death or long-term health risks.



This symbol indicates operations which, if not carried out correctly, may cause damage to the machine and/or injury to people.

2.1.3 Other symbols



DANGER: LIVE COMPONENTS
This symbol indicates operations which, if not carried out correctly, lead to electric shocks with lethal consequences.



DANGER: FLAMMABLE MATERIAL
This symbol indicates the presence of flammable materials.



DANGER: BURNING
This symbol indicates the risks of burns due to high temperatures.



DANGER: CRUSHING OF LIMBS
This symbol indicates the presence of moving parts: danger of crushing of limbs.



WARNING: MOVING PARTS
This symbol indicates that you must keep limbs away from moving mechanical parts; danger of crushing.



DANGER: EXPLOSION

This symbol signals places where an explosive atmosphere may be present. An explosive atmosphere is defined as a mixture - under atmospheric conditions - of air and flammable substances in the form of gases, vapours, mist or dust in which, after ignition has occurred, combustion spreads to the entire unburned mixture.



PERSONAL PROTECTION EQUIPMENT

These symbols indicate the equipment that must be worn and kept by the operator for protection against threats against safety and/or health while at work.



OBLIGATION TO ASSEMBLE THE COVER AND ALL THE SAFETY AND PROTECTION DEVICES

This symbol signals the obligation to reassemble the cover and all the safety and protection devices of the burner after any maintenance, cleaning or checking operations.



ENVIRONMENTAL PROTECTION

This symbol gives indications for the use of the machine with respect for the environment.



IMPORTANT INFORMATION

This symbol indicates important information that you must bear in mind.

- This symbol indicates a list.

Abbreviations used

Ch.	Chapter
Fig.	Figure
Page	Page
Sec.	Section
Tab.	Table

2.1.4 Delivery of the system and the instruction manual

When the system is delivered, it is important that:

- the instruction manual is delivered to the user by the system manufacturer, with the recommendation to keep it in the room where the heat generator is to be installed.
- The instruction manual shows:
 - the serial number of the burner;

.....

- the address and telephone number of the nearest Assistance Centre;

.....

- The system supplier must carefully inform the user about:
 - the use of the system;
 - any further tests that may be required before activating the system;
 - maintenance, and the need to have the system checked at least once a year by a representative of the manufacturer or another specialised technician.
 To ensure a periodic check, the manufacturer recommends the drawing up of a Maintenance Contract.

2.2 Guarantee and responsibility

The manufacturer guarantees its new products from the date of installation, in accordance with the regulations in force and/or the sales contract. At the moment of the first start-up, check that the burner is integral and complete.



ATTENTION

Failure to observe the information given in this manual, operating negligence, incorrect installation and carrying out of non authorised modifications will result in the annulment by the manufacturer of the guarantee that it supplies with the burner.

In particular, the rights to the guarantee and the responsibility will no longer be valid, in the event of damage to things or injury to people, if such damage/injury was due to any of the following causes:

- incorrect installation, start-up, use and maintenance of the burner;
- improper, incorrect or unreasonable use of the burner;
- intervention of unqualified personnel;
- carrying out of unauthorised modifications on the equipment;
- use of the burner with safety devices that are faulty, incorrectly applied and/or not working;
- installation of untested supplementary components on the burner;
- powering of the burner with unsuitable fuels;
- faults in the fuel supply system;
- continuation of use of the burner when a fault has occurred;
- repairs and/or overhauls incorrectly carried out;
- modification of the combustion chamber with inserts that prevent the regular development of the structurally established flame;
- insufficient and inappropriate surveillance and care of those burner components most likely to be subject to wear and tear;
- use of non-original components, including spare parts, kits, accessories and optional;
- force majeure.

The manufacturer furthermore declines any and every responsibility for the failure to observe the contents of this manual.

The manufacturer's warranty is subject to the correct combination of burner, devices and applications, and their configuration according to the manufacturer's instructions and guidelines. All hydraulic system components suitable for the use of biofuel and supplied by the manufacturer will be identified as biocompatible. The warranty does not cover any damage resulting from the use of components that are not identified as biofuel mixtures. If in doubt, do not hesitate to contact the manufacturer for further indications.

If burners with fuels containing >10% biological mixture are used, the components of the hydraulic system may be damaged and the warranty would expire. The hydraulic system consists of:

- Pump
 - Hydraulic jack (where applicable)
 - Valve block
 - Oil hoses (considered as consumables)
- 1 Regardless of any warranty provided by the manufacturer regarding normal use and manufacturing defects, if fuels that do not meet the relevant standards are used, fuel has not been correctly stored, or the equipment used is not compatible, in the event of failures directly or indirectly attributable to such improper storage and/or non-compliance with this guide, no warranty or liability will be accepted - tacitly or expressly - by the manufacturer.
 - 2 The manufacturer has carefully chosen the specifications of biocompatible components, including flexible oil hoses to protect the pump, safety valve and nozzle. The manufacturer's warranty is subject to the use of original components, including oil hoses.
 - 3 The manufacturer's warranty does not cover defects resulting from incorrect commissioning or maintenance by maintenance technicians not qualified by the manufacturer, as well as any problems found on the burner resulting from external causes.

2.3 Guide to the use of biofuel mixtures

Introduction

Given the growing focus on renewable and sustainable energy, the use of biofuels is set to increase. The Manufacturer is committed to promoting energy conservation and using renewable energy from sustainable sources, including liquid biofuels, however, when planning the use of these fuels, certain technical aspects must be taken into account to reduce equipment failure or the risk of fuel leakage.

Liquid biofuel is a generic description used for oil from many renewable raw materials. These types of oil must be considered and treated differently from the usual mineral and fossil fuels, as they are generally more acidic and less stable.

This requires an integrated approach to the specification of the liquid biofuel, fuel storage, oil supply line and ancillary equipment and, more importantly, oil filtration and the burner itself.

The specification of the FAME (fatty acid methyl ester) liquid biofuel is of key importance for reliable operation of the equipment.

The use of fuel up to B100 (FAME component according to EN 14214) is permitted.

The use of HVO fuel according to EN 15940 is permitted. Fuel mixtures with more than 7% FAME component in the HVO are not permitted.

When choosing the Manufacturer's oil products in which biofuels will be used, make sure that biocompatible burner and components are present. Follow the supplied instructions for oil storage and filtration.

The end user is responsible for thoroughly verifying the potential risks associated with the introduction of a biofuel mixture and the sustainability of the appliances and the applicable installation.

Regardless of any warranty provided by the Manufacturer regarding normal use and manufacturing defects, if fuels that do not meet the relevant standards are used, if fuel has not been correctly stored, or the equipment used is not compatible, in the event of failures directly or indirectly attributable to such improper storage and/or non-compliance with this guide, no warranty or liability will be accepted - tacitly or expressly - by the Manufacturer.

2.3.1 Information and general instructions

To ensure consistency, the fuel supplier must be able to demonstrate compliance with a recognised quality control and management system to ensure that high standards are met in the storage, mixing and delivery processes.

The installation of the oil storage tank and its accessories must also be prepared BEFORE introducing the liquid biofuel.

Checks and preparation must include:

- For new installations, ensure that all materials and sealing devices in the oil storage and supply line to the burner are compatible with biofuels. A good quality biocompatible oil filter and a 60 micron secondary filter must be present for all tank installations to protect the burner from contamination.
- Where an oil storage tank is to be used, in addition to checking the above materials, it will be necessary to inspect the tank to check its conditions and to ensure that no water or other contamination is present. The Manufacturer strongly recommends cleaning the tank and replacing the oil filters before supplying the biofuel; otherwise, given its hydropscopic nature, the biofuel will effectively clean the tank, absorb the water inside it, which in turn will cause equipment failures that will not be covered by the manufacturer's warranty.
- Depending on the capacity of the oil storage tank and the use of oil, fuels may remain inside the tank for a considerable period of time, therefore, the manufacturer recommends to refer to the oil distributor on the use of additional biocides inside the fuel in order to prevent microbial growth inside the tank.

The manufacturer suggests contacting fuel suppliers and/or service companies for instructions on fuel filtration. Pay particular attention to dual fuel applications where oil can be stored for long periods of time.

- The burner must be set according to the application of the appliance and set up by checking that all combustion parameters comply with the recommendations in the technical manual of the appliance.
- The manufacturer recommends that burner line and oil pump filters should be checked and, if necessary, replaced at least every 4 months during burner operation. Before the burner is started after a long period of downtime and more frequently in case of contamination, it is recommended to carry out a test operating cycle and then replace the filter. This operation could help to clean the line before contaminating the new filter. Particular attention should be paid during the verification and inspection for fuel leaks from sealing devices, seals or gaskets and hoses.

2.3.2 Product liability disclaimer

PLEASE READ THE FOLLOWING STATEMENT CAREFULLY. THE CUSTOMER ACCEPTS AND AGREES TO BE BOUND BY THIS STATEMENT WHEN PURCHASING BURNERS AND/OR BIOCOMPATIBLE COMPONENTS FROM THE MANUFACTURER.

Although the information and recommendations (hereinafter "Information") contained in this guide are presented in good faith, believed to be correct and carefully checked, the Manufacturer, and its subsidiaries, do not state or ensure their completeness or accuracy. The Information is provided on condition that the persons receiving it determine for themselves whether it is suitable for their own purposes before use. Under no circumstances shall the Manufacturer (and its subsidiaries) be liable for damages of any nature whatsoever resulting from the use of, or reliance on, the Information.

Beyond what is provided herein, the Manufacturer and its subsidiaries do not apply any additional warranty, tacit or express, regarding the biocompatible burner, including the warranty of merchantability or suitability for a particular purpose or use.

In no event shall the Manufacturer (and its subsidiaries) be liable for any indirect, incidental, special or consequential damages, including, without limitation, lost profits, damages for loss of business profits, business interruption, loss of business information, loss of equipment or other pecuniary loss or compensation for services, whether or not aware of the possibility of such damages.

With the exception of personal injury, the manufacturer's liability is limited to the customer's right to return defective/non-compliant products as provided for in the relevant product warranty.

3 Safety and prevention

3.1 Introduction

The burners have been designed and built in compliance with current regulations and directives, applying the known technical safety rules and envisaging all the potential danger situations.

It is necessary, however, to bear in mind that the imprudent and clumsy use of the equipment may lead to situations of death risk for the user or third parties, as well as the damaging of the burner or other items. Inattention, thoughtlessness and excessive confidence often cause accidents; the same applies to tiredness and sleepiness.

It is a good idea to remember the following:

- The burner must only be used as expressly described. Any other use should be considered improper and therefore dangerous.

Specifically:

it can be applied to boilers operating with water, steam, diathermic oil, and to other uses expressly named by the manufacturer;

the type and pressure of the fuel, the voltage and frequency of the electrical power supply, the minimum and maximum deliveries for which the burner has been regulated, the pressurisation of the combustion chamber, the dimensions of the combustion chamber and the ambient temperature must all be within the values indicated in the instruction manual.

- Modification of the burner to alter its performance and destinations is not allowed.
- The burner must be used in exemplary technical safety conditions. Any disturbances that could compromise safety must be quickly eliminated.
- Opening or tampering with the burner components is not allowed, apart from the parts requiring maintenance.
- Only those parts envisaged by the manufacturer can be replaced.



The manufacturer guarantees safety and proper operation only if all burner components are intact and correctly positioned.

3.2 Personnel training

The user is the person, body or company that has acquired the machine and intends to use it for the specific purpose. He is responsible for the machine and for the training of the people working around it.

The user:

- undertakes to entrust the machine exclusively to suitably trained and qualified personnel;
- undertakes to inform his personnel in a suitable way about the application and observance of the safety instructions. With that aim, the user undertakes to ensure that everyone knows the use and safety instructions for his own duties;
- Personnel must observe all the danger and caution indications shown on the machine.
- Personnel must not carry out, on their own initiative, operations or interventions that are not within their province.
- Personnel must inform their superiors of every problem or dangerous situation that may arise.
- The assembly of parts of other makes, or any modifications, can alter the characteristics of the machine and hence compromise operating safety. The manufacturer therefore declines any and every responsibility for any damage that may be caused by the use of non-original parts.

In addition:



- must take all the measures necessary to prevent unauthorised people gaining access to the machine;
- the user must inform the manufacturer if faults or malfunctioning of the accident prevention systems are noticed, along with any presumed danger situation;
- personnel must always use the personal protective equipment envisaged by legislation and follow the indications given in this manual.

4 Technical description of the burner

4.1 Burner designation

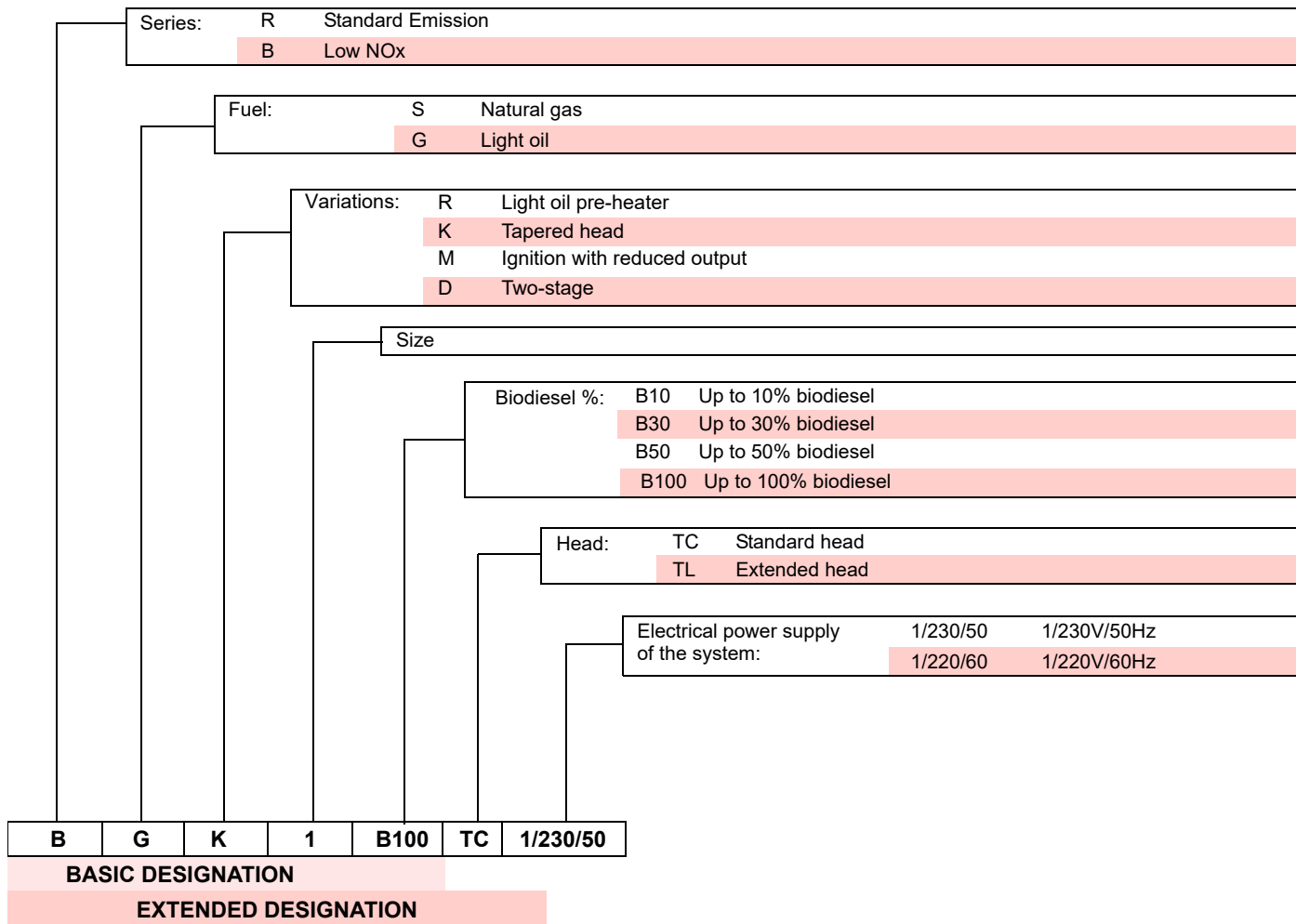

4.2 Models available

Designation	Combustion head	Voltage	Code
BGK1 B100	TC	1/230/50	20204457
BGK2 B100	TC	1/230/50	20204458
BGK3 B100	TC	1/230/50	20204459

Tab. A

4.3 Technical data

Model		BGK1 B100	BGK2 B100	BGK3 B100
Delivery ⁽¹⁾	kg/h ⁽³⁾	1.6 ÷ 3.1	2.8 ÷ 5.2	3.9 ÷ 6.3
Thermal output ⁽¹⁾	kW	17.8 ÷ 35.6	32 ÷ 59.3	45.0 ÷ 73.0
Fuel storage temperature	min.	No lower than the turbidity point		
Operation		Intermittent (FS1)		
Use		Boilers: water and diathermic oil		
Ambient temperature	°C	- 5 ÷ 40		
Combustion air temperature	°C max	40		
Pump	bar	Pressure: 8 ÷ 15		
Noise levels ⁽²⁾				
Sound pressure	dB(A)	62	63	62
Sound power		73	74	73
Burner weight	kg	13	13	16.5

Fuel	Viscosity mm ² /s		Temperature °C	Standards	Test
	min.	max			
Light oil - B10	4.0	6.0	20	EN 267	EN ISO 3104
B30 ⁽³⁾	2.0	4.5	40	-	EN ISO 3104
B50	2.0	4.5	40	-	EN ISO 3104
B100	3.5	5.0	40	EN 14213	EN ISO 3104
HVO	2.0	4.5	40	-	EN ISO 3104

Tab. B

- (1) Reference conditions: Ambient temperature 20°C - Barometric pressure 1013 mbar – Altitude 0 m above sea level. (Hi B30= 11.45 kWh/kg)
- (2) Sound pressure measured in manufacturer's combustion laboratory, with burner operating on test boiler and at maximum output. The sound power is measured using the "Free Field" method, required by the EN 15036 standard, and according to an "Accuracy: Category 3" measurement, as described in EN ISO 3746.
- (3) **Burner leaves the factory set up for biofuel B30 operation.**

4.4 Electrical data

Model		BGK1 B100	BGK2 B100	BGK3 B100
Electrical power supply		Single-phase, ~ 50Hz 230V ± 10%		
Motor	A	0.9		1.8
	rpm	2750		2800
	rad/s	288		294
Capacitor	µF	4	4	8
Ignition transformer		Secondary 18 kV / 25 mA		
Absorbed electrical power	kW	0.27	0.27	0.46
Protection level		IP 40		

Tab. C

4.5 Burner equipment

Flange with insulating gasket	No. 1
Screw and nuts for flange.....	No. 1
Remote reset connection	No. 1
Screws and nuts for fixing the flange to the boiler.....	No. 4
Recirculation pipe	No. 1
Flexible hoses with nipples.....	No. 2
7-pin plug.....	No. 1
Installer booklet	No. 1
Spare Parts List.....	No. 1

Remote reset kit

The burner has a remote reset kit (**RS**) consisting of a connection and a push-button operating at a distance of 20 metres max.

In order to install it, remove the safety lockout device installed at the factory and insert the one supplied with the burner (see wiring diagram).

4.6 Maximum dimensions

The maximum dimensions of the flange and burner are given in Fig. 1.

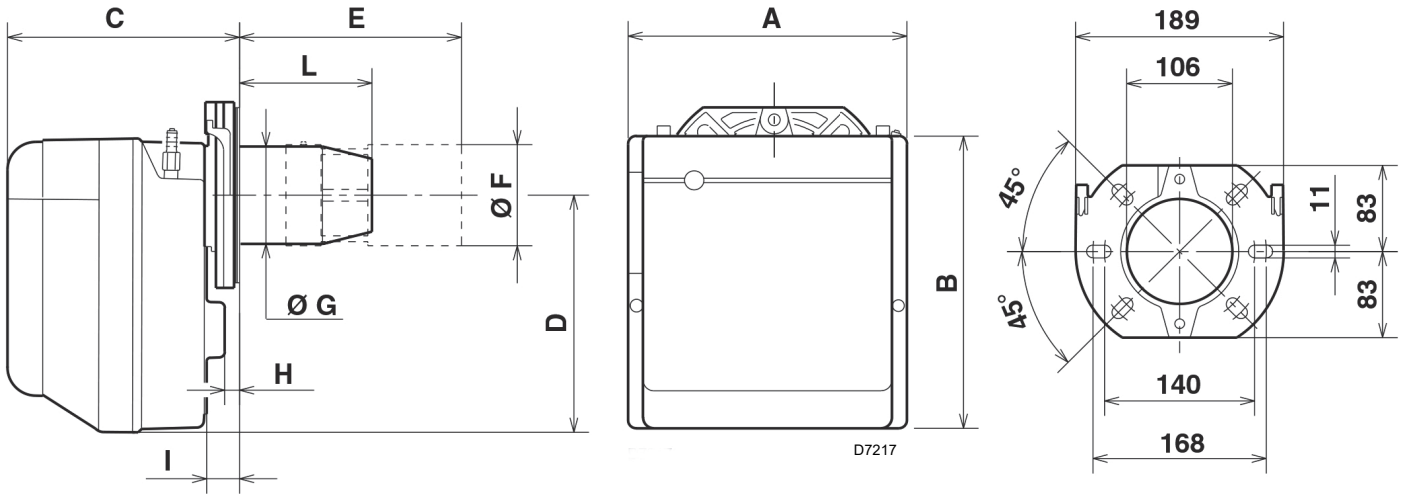

Fig. 1

Type	A	B	C	D	E	ØF	ØG	H	I	L
BGK1	255	280	202	230	192	87	89	10	28	107
BGK2	255	280	202	230	197	90	89	10	28	115
BGK3	300	345	230	285	222	90	89	12	34	140

4.7 Burner description

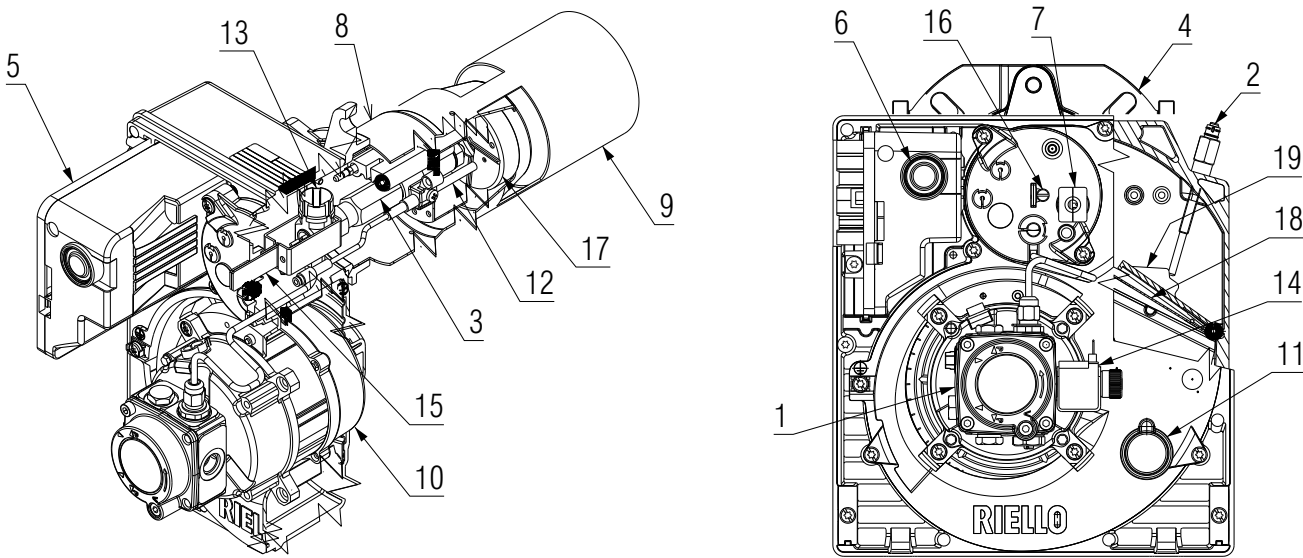

Fig. 2

- 1 Oil pump
- 2 Air damper adjustment screws
- 3 Nozzle holder with diesel heater
- 4 Flange with insulating gasket
- 5 Control box
- 6 Reset button with lock-out signal
- 7 Flame sensor
- 8 Flame pipe
- 9 Flue gas recirculation tube
- 10 Motor
- 11 Capacitor
- 12 Optical fiber
- 13 Start enable thermostat
- 14 Operating solenoid valve
- 15 Head calibration rod
- 16 Head adjustment screw
- 17 Air diffuser

- 18 Air damper
- 19 Damper anti-slaming device



ATTENTION

In order to meet the indicated regulatory requirements, the burner must be protected by a panel or boiler door.

This protection can only be removed with a tool.



ATTENTION

PUMP OPERATION

A periodic check of the pump pressure operation is strongly recommended (annually or even better every six months, if the burner is operating in continuous mode). If the value is less than 1 bar from the initial setting, check that the pump and line filters are clean. If the pressure cannot be restored, please replace the pump.

4.8 Firing rate

The burner output is chosen from within the diagram area (Fig. 3).



In order to ensure the correct operation of the burner, start-ups must always take place within the relevant ignition range.



The firing rates (Fig. 3) were obtained at an ambient temperature of 20°C, at a barometric pressure of 1013 mbar (about 0 m a.s.l.) and with the combustion head regulated as indicated on page 23.

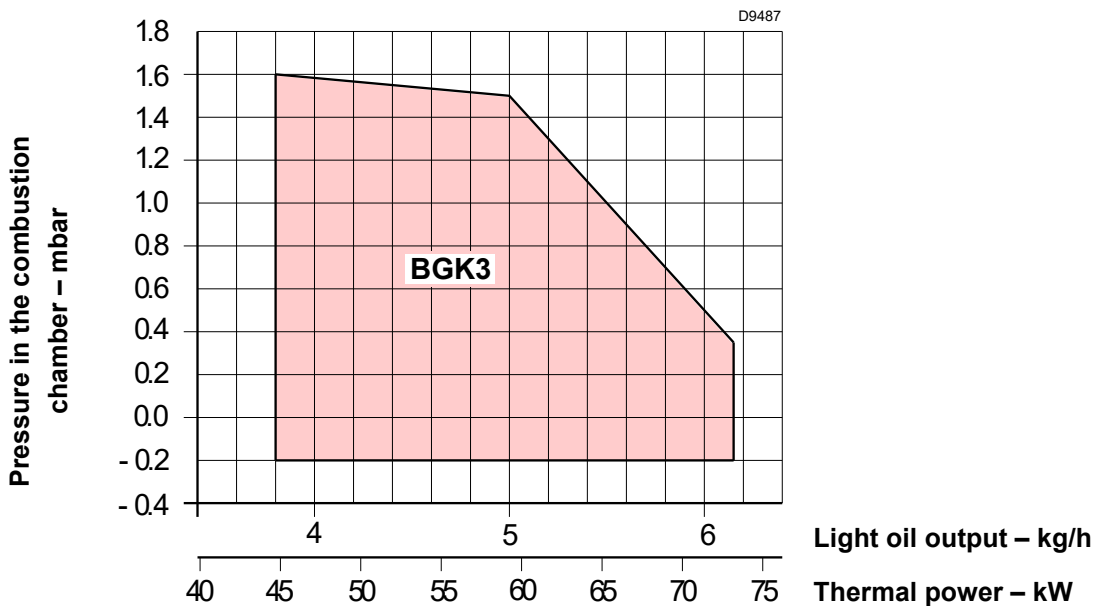
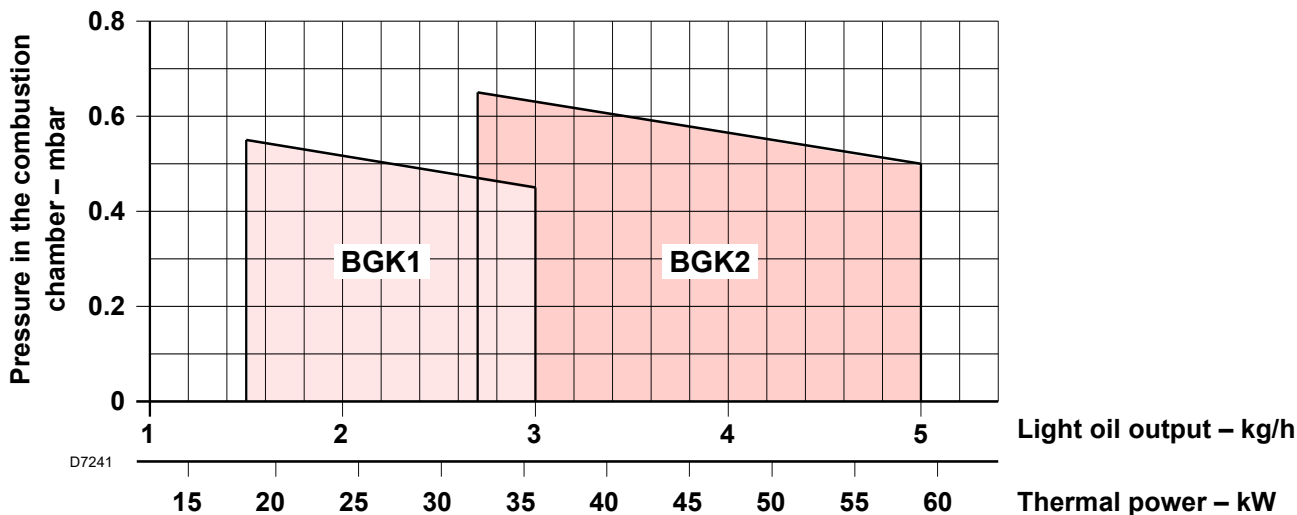

Fig. 3

4.8.1 Test boiler

The firing rate has been defined on test boilers according to EN 267 standard.

4.8.2 Commercial boilers

The burner-boiler matching is assured if the boiler conforms to EN 303 and the combustion chamber dimensions are similar to those shown in the diagram EN 267.

For applications where the boiler does not conform to EN 303, or where the combustion chamber is much smaller than the dimensions given in EN 267, please consult the manufacturers.

4.9 Electrical control box

The control box is a control and supervision system for forced draught burners, for intermittent operation (at least one controlled shutdown every 24 hours).

Important notes



To avoid accidents, material or environmental damage, observe the following instructions!

The control box is a safety device! Avoid opening or modifying it, or forcing its operation. The Manufacturer cannot assume any responsibility for damage resulting from unauthorised work!

- All interventions (assembly and installation operations, assistance, etc.) must be carried out by qualified personnel.
- Before modifying the wiring in the control box connection area, fully disconnect the system from the power supply (omnipolar separation).
- Protection against electrocution from the control box and all connected electric components is obtained with the correct assembly.
- Before any intervention (assembly and installation operations, assistance, etc.), ensure the wiring is in order and that the parameters are correctly set, then make the safety checks.
- Falls and collisions can negatively affect the safety functions. In this case, the control box must not be operated, even if it displays no evident damage.

For safety and reliability, comply with the following instructions:

- avoid conditions that can favour the development of condensate and humidity. Otherwise, before switching on again, make sure the control box is perfectly dry.
- Static charges must be avoided since they can damage the control box's electronic components when touched.

Installation notes

- Make sure that the electrical wiring inside the boiler complies with national and local safety regulations.
- Install switches, fuses, earth connection etc. in compliance with local regulations.
- Do not confuse the powered conductors with the neutral ones.
- Ensure that spliced wires cannot get into contact with neighbouring terminals. Use adequate ferrules.
- Arrange the H.V. ignition cables separately, as far as possible from the control box and the other cables.
- When wiring the unit, make sure that AC 230 V mains voltage cables are run strictly separate from extra low-voltage cables to avoid risks of electrical shock hazard.



Condensation, the formation of ice and the entry of water are prohibited!

To remove the control box from the burner it is necessary to (Fig. 4):

- disconnect all the connectors connected to it, all the plugs, the high voltage cables and the earth wire (TB);
- loosen the screw (A) and pull the control box in the direction of the arrow.

To install the control box it is necessary to:

- tighten the screw (A) to a tightening torque of 1 to 1.2 Nm;
- reconnect all previously disconnected connectors, making sure to connect the 7 pin power plug as the final step.

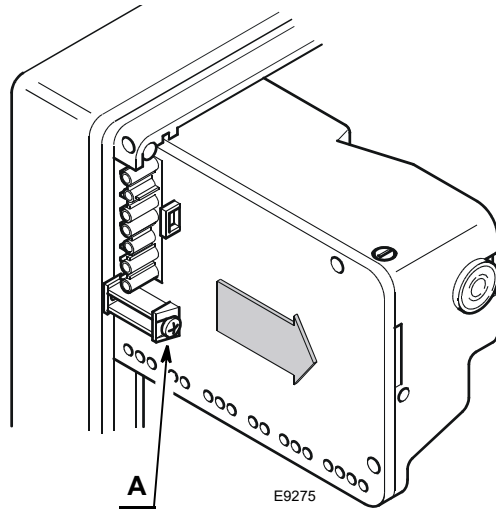

Fig. 4

NOTE:

The burners have been approved for intermittent operation. This means they must stop at least once every 24 hours in order to allow the electrical control box to check its efficiency upon start-up. The boiler limit thermostat (TL) normally ensures the stopping of the burner. If this is not the case, it is necessary to apply a timer switch in series to the limit thermostat (TL) that turns off the burner at least once every 24 hours.

Electrical connection of the flame sensor

It is important for signal transmission to be almost totally free of any disturbances or loss:

- Always separate the flame sensor cables from the other cables:
 - the line capacity reduces the magnitude of the flame signal.

Technical data

Mains voltage	AC 210... 230 V -15 % / +10 %
Mains frequency	50/60 Hz ±5%
Built-in fuse	T4A 250V
Energy consumption	40 VA
Integrated ignition device peak voltage	18 kV pk
Integrated ignition device peak current	25 mArms
Integrated ignition device operating cycle	1/minute

Tab. D

5 Installation

5.1 Notes on safety for the installation

After carefully cleaning all around the area where the burner is to be installed, and arranging for the environment to be illuminated correctly, proceed with the installation operations.



All the installation, maintenance and disassembly operations must be carried out with the electricity supply disconnected.



The installation of the burner must be carried out by qualified personnel, as indicated in this manual and in compliance with the standards and regulations of the laws in force.



The combustion air inside the boiler must be free from hazardous mixes (e.g.: chloride, fluoride, halogen); if present, it is highly recommended to carry out cleaning and maintenance more frequently.

5.2 Instructions to avoid burnout or bad combustion of the burner

- 1 The burner can not be installed outside as it is suitable for operation in closed rooms only.
- 2 The premises the burner operates in must have openings for the air need for the combustion.
To be sure about this, you have to control CO₂ and CO in the exhaust gases with all the windows and doors closed.
- 3 If there are air extractors in the premises the burner works, make sure that there are openings for air to be taken in that are big enough to ensure the required air change; In any case, check that when the burner stops the extractors do not draw hot fumes from pipes through the burner.
- 4 When the burner is stopped, the smoke pipe must be kept open and a natural draft created in the combustion chamber. If the smoke pipe is closed, the burner must be drawn back till the extraction of blast tube from the furnace.
Before operating in this way take the voltage off.

5.3 Handling

The transport weight is given in chapter 4.3 page 9.

Observe the permissible ambient temperatures for storage and transport: -20 + 70°C, with max. relative air humidity 80%.



After positioning the burner near the installation point, correctly dispose of all residual packaging, separating the various types of material.



Before proceeding with the installation operations, carefully clean all around the area where the burner will be installed.



The operator must use the required equipment during installation.

5.4 Preliminary checks

Checking the consignment



After removing all the packaging, check the integrity of the contents. In the event of doubt, do not use the burner; contact the supplier.



The packaging elements (wooden cage or cardboard box, nails, clips, plastic bags, etc.) must not be abandoned as they are potential sources of danger and pollution; they should be collected and disposed of in the appropriate places.

Checking the characteristics of the burner

Check the identification label (Fig. 5) of the burner, showing:

- the model **A** (Fig. 5) and type of burner **B**;
- the year of manufacture, in cryptographic form **C**;
- the serial number **D**;
- the absorbed electrical power **E**;
- the types of fuel used **F**;
- the minimum and maximum possible output data of the burner **G** (see Firing rate)
- the weight of the burner **H**).

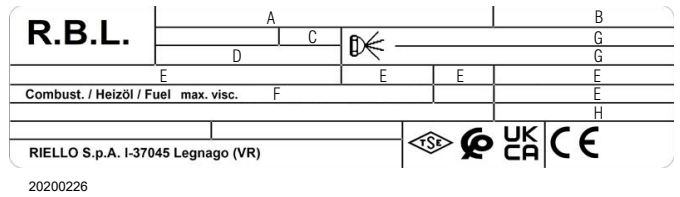

Fig. 5



ATTENTION

The burner output must be within the boiler's firing rate.



ATTENTION

A burner label that has been tampered with, removed or is missing, along with anything else that prevents the definite identification of the burner makes any installation or maintenance work difficult.

5.5 Installer notes for the use of biofuel

- When installing the burner, make sure that the fuel to be used complies with the manufacturer's specifications (see chapters "Technical data" and "Instructions for the use of biofuel mixtures").
- If a biomass mixture is used, the installer shall ask end users whether their fuel supplier can prove that the fuel mixture complies with the relevant standards.
- Check that the materials used in the construction of the oil tank and ancillary equipment are suitable for biofuels; if not, they must be upgraded or replaced with biocompatible parts.
- Pay particular attention to the oil storage tank and the supply to the burner.
The manufacturer recommends that existing oil storage tanks are cleaned and inspected and any trace of water is removed BEFORE adding the biofuel (Contact the tank manufacturer or oil supplier for further indications). Failure to comply with these recommendations will increase the risk of contamination and possible equipment failure.
- The oil filters in the line must be replaced ensuring that they are biocompatible.
The Manufacturer recommends the use on the tank of a good quality oil filter compatible with biofuel and a 60 micron secondary filter to protect the burner pump and the nozzle from contamination.
- The burner oil components and hoses must be suitable for the use of biofuel (If in doubt, check with the supplier).
- The burner must be commissioned and the combustion parameters must be set according to the recommendations of the appliance manufacturer.
- Perform regular visual checks for oil leaks from sealing devices, seals or gaskets, and hoses.
- It is strongly recommended to check and replace oil filters every 4 months when using biofuel; more regularly if contamination has occurred.

5.6 Operating position



The burner is designed to work only in positions **1** and **2**.

Installation **1** is preferable, as it is the only one that allows the maintenance operations as described in this manual.

Installation **2** allows the operation but not the maintenance with the appliance coupled to the boiler.

Any other position could compromise the correct operation of the appliance.



Any other position could compromise the correct operation of the appliance.

Installations **3**, **4** and **5** are forbidden for safety reasons.

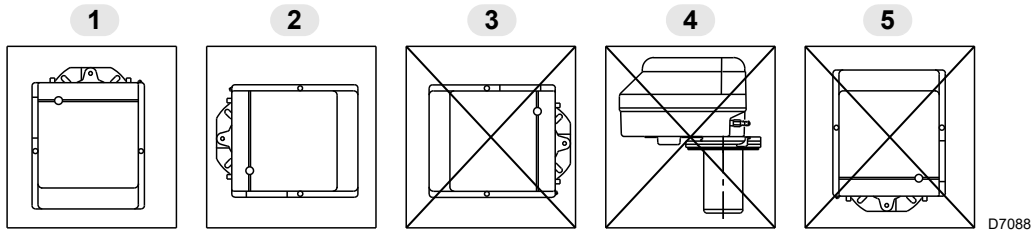

Fig. 6

5.7 Securing the burner to the boiler



Provide an adequate lifting system of the burner.



ATTENTION

With some boilers, the CO values may exceed those stated in this manual. To lower these emissions, use the supplied recirculation tube.

To install the burner on the boiler, do the following:

- Fit the recirculation pipe 1) (Fig. 8) onto the burner blast tube 2) and secure it with the screw 3).
- Fit the screw and the two nuts 9) on flange 4) (Fig. 9).
- If necessary, widen the holes of the insulating gasket 5) Fig. 7.
- Fix the flange 4) to the boiler door 6) (Fig. 10) using screws 7) and (if necessary) the nuts 8) interposing the insulating gasket 5).



ATTENTION

In any event, make sure that the combustion head crosses the entire thickness of the boiler door.



ATTENTION

The seal between burner and boiler must be airtight.

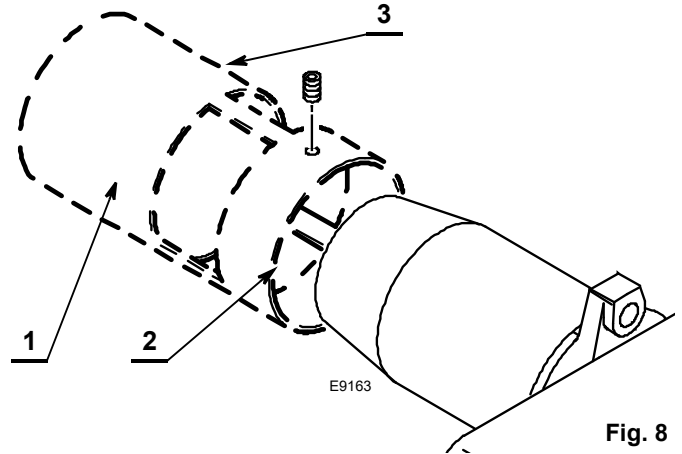

Fig. 8

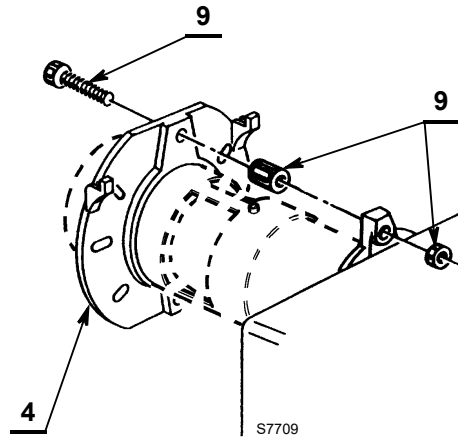

Fig. 9

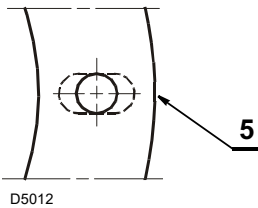

Fig. 7

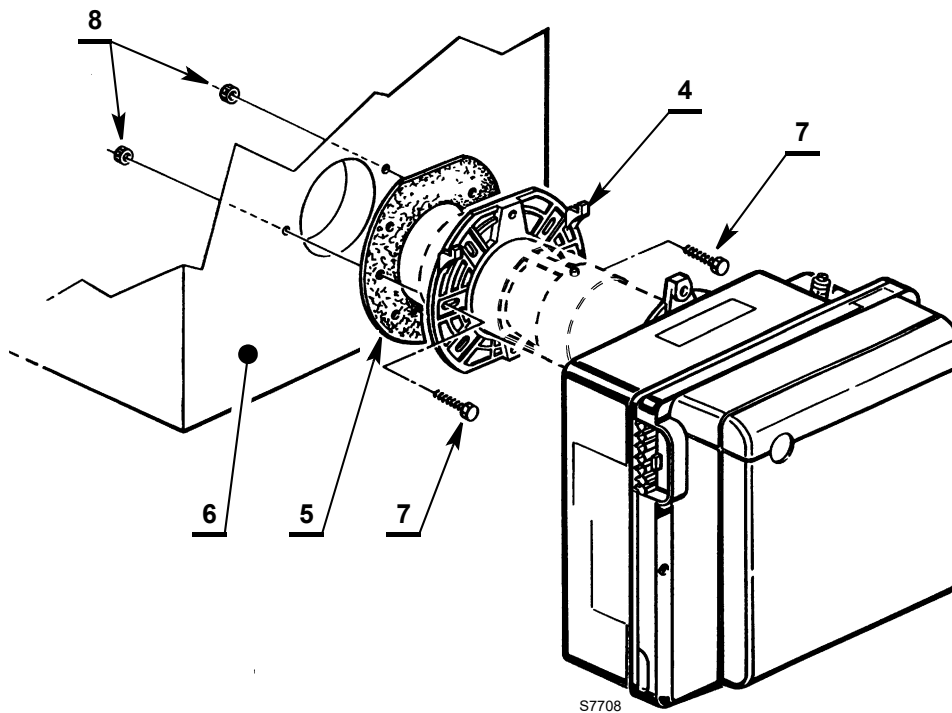

Fig. 10

5.8 Combustion head adjustment

The adjustment of the combustion head varies depending on the burner output. To adjust it, proceed as follows:

- Turn the adjustment screw 2)(Fig. 11) clockwise or anti-clockwise until the notch on the regulating rod 3)(Fig. 11) lines up with the outside surface of the head cover 1)(Fig. 11).
- In the example, the regulating rod 3) is calibrated to notch 2; this means that the BGK3 burner is adjusted for a flow rate of 4.9 Kg/h with pump pressure at 12 bar and with the use of a 1.25 GPH nozzle, as indicated in page 23.

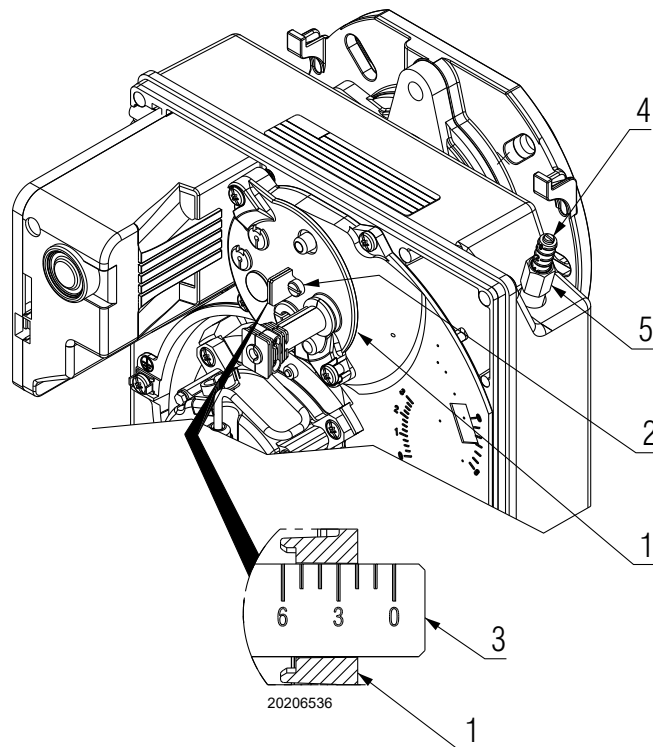

Fig. 11

5.9 Air damper setting

To vary the air damper setting proceed as follows:

- Loosen the nut 5)(Fig. 11) and calibrate the damper by acting on the screw 4)(Fig. 11).
- When the operation is completed, tighten nut 5) again.

For BGK1 and BGK3 burners:

When the burner shuts down, the air damper automatically closes up to a max. flue depression of 0.5 mbar.

For BGK2 burner:

When the burner stops, the air damper remains open.

5.10 Electrode adjustment



ATTENTION

The measures in Fig. 12 must be complied with.

- To reach the electrodes perform the operation described, see paragraph **“It is strongly recommended to check and replace oil filters every 4 months when using biofuel; more regularly if contamination has occurred.”** on page 14.

To adjust, proceed as follows:

- place the diffuser disc holder assembly 3)(Fig. 12) on nozzle holder 2)(Fig. 12) and secure with screw 4)(Fig. 12).
For any adjustment of the electrode assembly 5) loosen the screw 6)(Fig. 12).

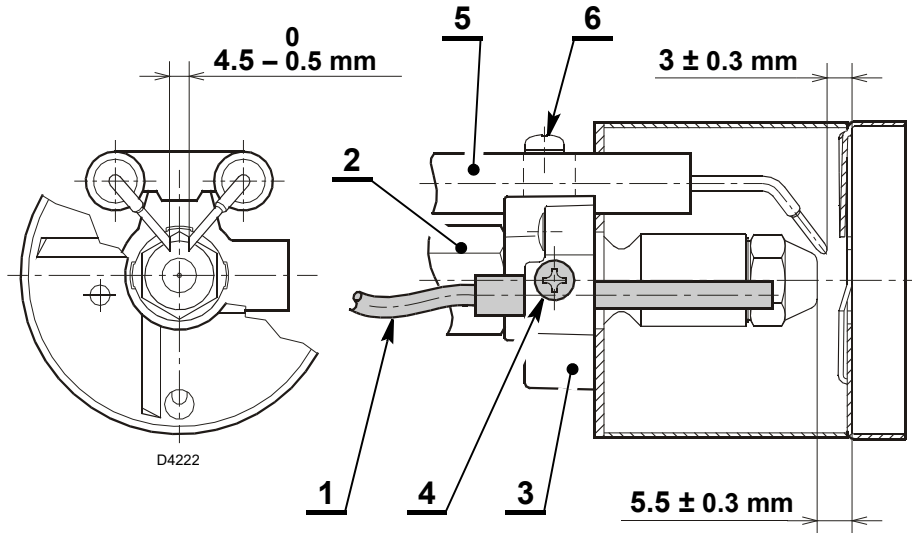

Fig. 12

5.11 Optical fiber positioning

To position the optical fiber, follow the procedure below:

- Insert the optical fiber 1)(Fig. 12) into the diffuser disc holder 3) and ensure that it reaches up to the end-of-stroke.
- Carefully tighten the screw 4)(Fig. 12) to secure the optical fiber 1)(Fig. 12).

5.12 Fuel heating

To ensure smooth ignition and operation even at low temperatures, the burner is equipped with a light oil heater in the combustion head.

The heater activates when the thermostats are closed. The burner start-up enabling is given by a thermostat placed on the nozzle holder once the optimal temperature for ignition has been reached. The heater remains on during operation and switches off when the burner stops.

5.13 Maintenance position

The nozzle, diffuser disc and electrodes can be reached in two ways:

1st Mode (Fig. 13):

- pull out the cables 2)(Fig. 13) from the control box, the flame sensor 8) and unscrew the nut 9) from the pump.
- Loosen the screws 10) and remove the nozzle holder assembly 1) by turning it to the right.
- Remove the cables 2) from the electrodes, loosen the screw 4)(Fig. 13) and remove the diffuser disc holder assembly 3) from the nozzle holder assembly 1).
- Hold the nozzle holder and screw the nozzle 6) using a wrench.
- Refit by following the procedure described above in reverse order.



When refitting the nozzle holder assembly, tighten the nut 9), as shown in Fig. 15.

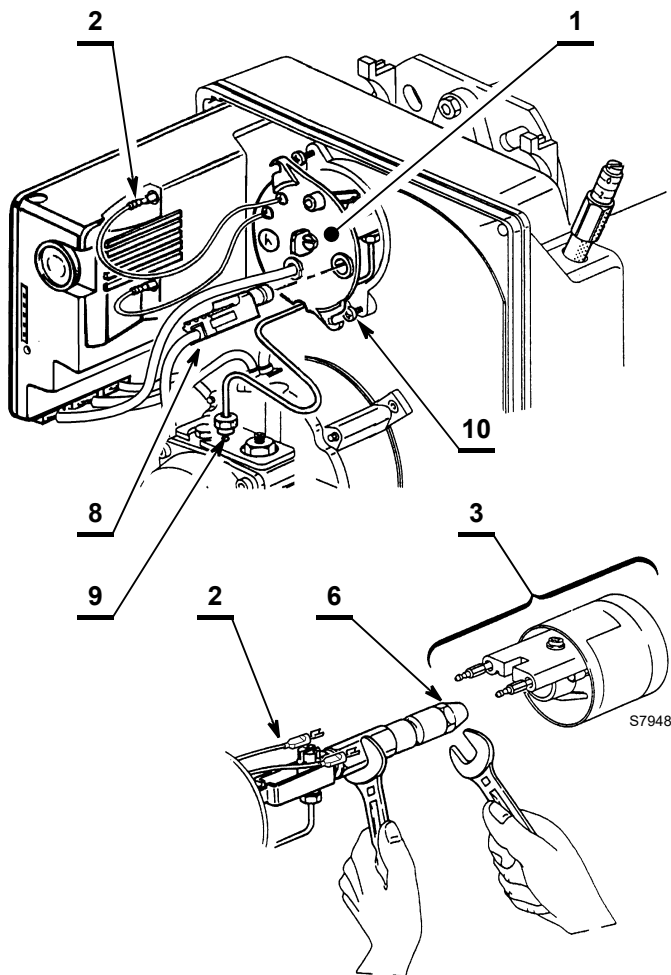

Fig. 13

2nd Mode (Fig. 13):

- Unscrew and remove the flange fastening nut to extract the burner from the boiler.
- Couple the burner to the flange 7) Fig. 14, loosen the screws 5) then remove the blast tube assembly 4).
- Loosen the screw 4)(Fig. 14) and remove the diffuser disc holder assembly 3) from the nozzle holder assembly 1).
- Completely unscrew the fixing screw 4)(Fig. 14) to remove the optical fiber 8) from the diffuser disc holder 3).
- Remove the cables 2) from the electrodes.
- Replace and correctly screw in the nozzle 6) tightening it as shown in Fig. 14.
- Refit by following the procedure described above in reverse order.

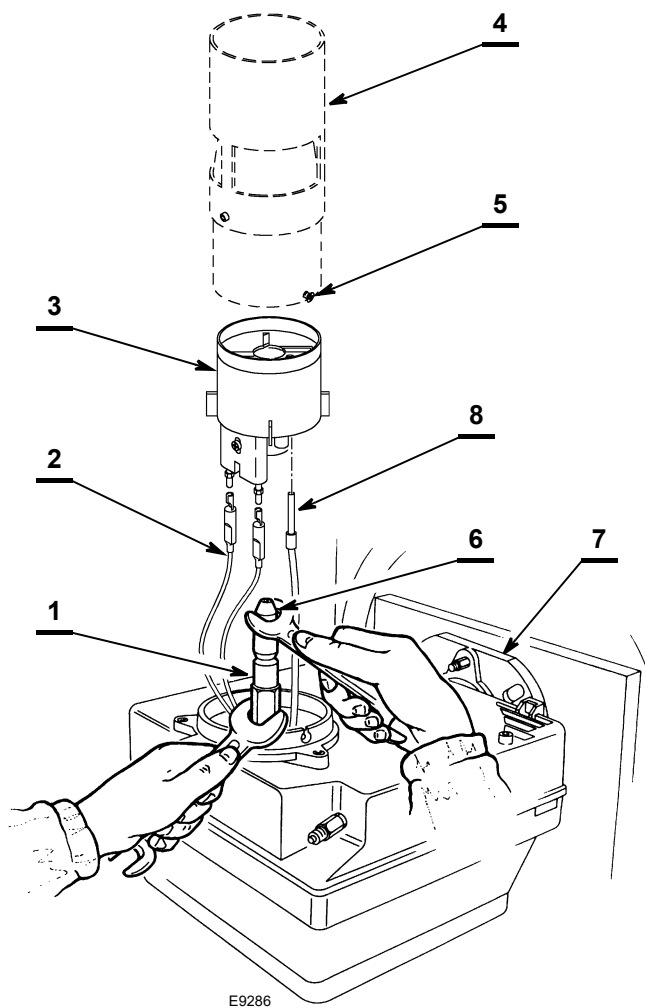

Fig. 14

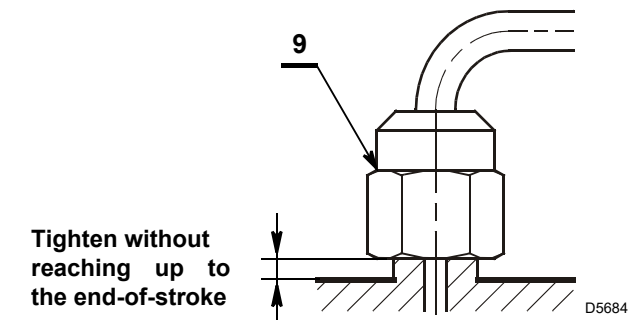

Fig. 15

5.14 Hydraulic systems



Explosion danger due to fuel leaks in the presence of a flammable source.

Precautions: avoid knocking, attrition, sparks and heat.

Make sure the fuel shut-off valve is closed before performing any operation on the burner.



ATTENTION

The fuel supply line must be installed by qualified personnel, in compliance with current standards and laws.

5.14.1 Fuel supply

The burner is designed to allow entry of the flexible oil lines on either side of the burner.

Depending on whether the outlet of the pipes is to the right or left of the burner, both the fixing plate 1) and the closing bracket 2)(Fig. 16) must be inverted.

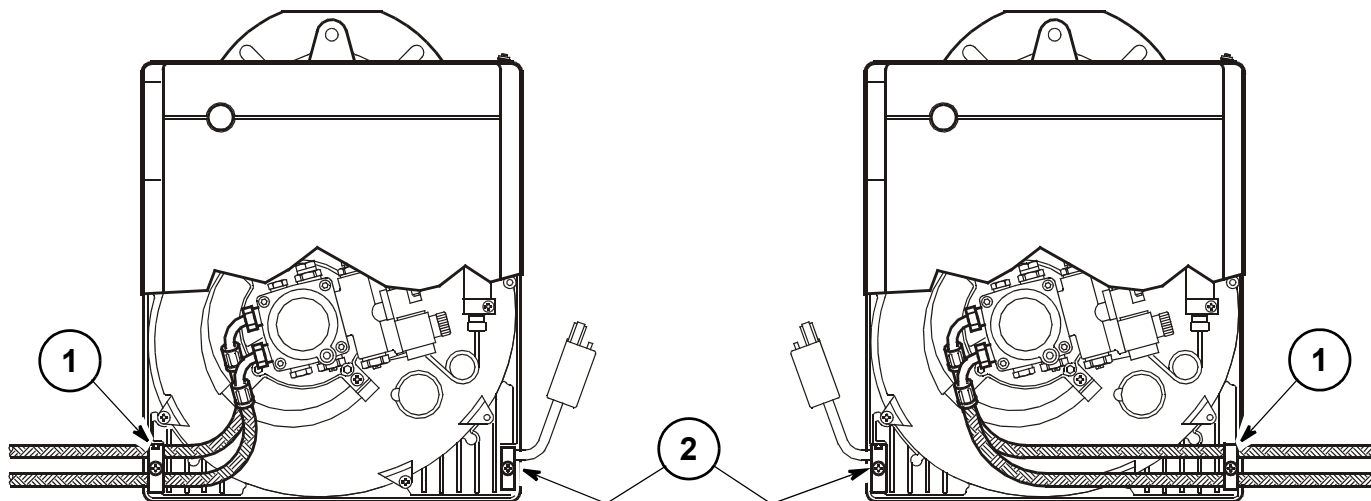

D5345

Fig. 16

5.14.2 Pump

The pump is designed to allow working with two pipes.

Before starting the burner, make sure that the fuel return pipe is not clogged.

Excessive back pressure (≥ 1 bar) would cause the pump seal to break, resulting in fuel leakage into the burner.



The suction plug 1) is made of plastic material. Once removed, it must not be used again.

In single pipe installations the plug on the return 2) must be absolutely made of steel.

The pump is provided with a delivery pressure regulating device 5). Pressure increases with clockwise rotation, vice versa in the opposite direction. The indicative sensitivity is about 1 bar per turn. The pressure is adjustable within a range of 8 to 15 bar.



It is recommended not to loosen knob 9) and to check its tightness periodically for safety reasons.



Check periodically the conditions of the flexible hoses.

It is necessary to install a filter on the fuel supply line.

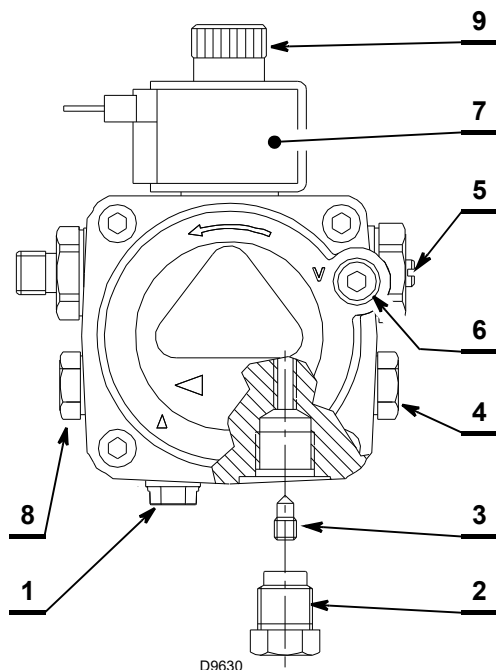

Fig. 17

- 1 Suction line
- 2 Return line
- 3 By-pass screw
- 4 Pressure gauge connection
- 5 Pressure adjuster
- 6 Vacuum connection
- 7 Valve
- 8 Auxiliary pressure test point
- 9 Knob



It is recommended to avoid excessive oxygenation of mixed fuels in places where light oil containing biodiesel is in use.

If possible, avoid using dual pipe systems where the circulating fuel returns to the tank.

If this cannot be avoided, ensure that the return pipe is normally below the surface of the fuel level inside the storage tank.



In the case of a two-pipe system, we recommend the use of a suitable degassing filter according to the connection diagram (see Fig. 18).

An example of a degassing filter is the Tigerloop B100.



When using light oil containing biomass mixture, it is essential to use oil hoses suitable for the use of biofuel.

For further information contact the Manufacturer.



The minimum fuel storage temperature must not be below the turbidity point.

5.14.3 Pressure adjustment

- The pump is calibrated in the factory at 12 bar.
- If necessary, recalibrate the pressure by acting on the screw 5) Fig. 17.

5.14.4 Single pipe pressure systems

Single pipe pressure systems (Fig. 18) have a positive fuel pressure at the burner inlet.

Typically they have the tank at a greater height than the burner or fuel pumping systems outside the burner.

For single pipe operation it is necessary to unscrew the return line plug 2), remove the by-pass screw 3) and screw the plug 2) back on with a tightening torque of 0.5 Nm.

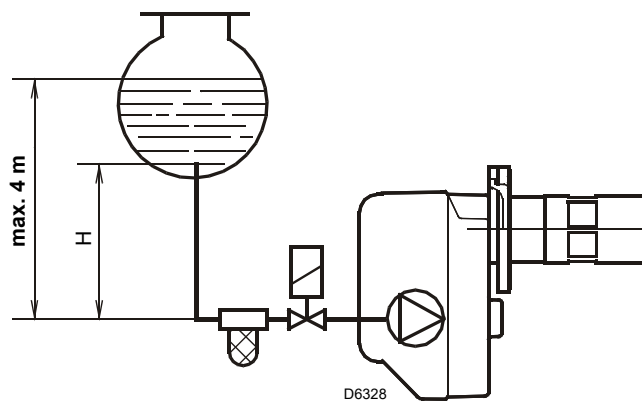

Fig. 18

H metres	L metres	
	Ø (8 mm)	Ø (10 mm)
0.5	10	20
1	20	40
1.5	40	80
2	60	100

Tab. E

- H = Difference in level
- L = Max. length of the suction line
- Ø = Internal pipe diameter



The installer must ensure that the supply pressure does not exceed 0.5 bar.
Beyond this value there is an excessive stress on the pump sealing element.

In the system of Fig. 18, the table shows the maximum indicative lengths for the supply line as a function of the difference in level, length and diameter of the fuel line.

5.14.5 Priming pump

In the Fig. 18 system, simply loosen the vacuumer connection 6) and wait for the fuel to escape.

In systems **A** and **B** of Fig. 19 start the burner and wait for the ignition. If the lockout occurs before the fuel arrives, wait at least 20 seconds, then repeat the operation.

The pump vacuum should not exceed a maximum of 0.4 bar (30 cm Hg).

Beyond this limit, gas is released from the fuel.



Oil pipes must be completely airtight.

5.14.6 Depressurized systems

Depressurized systems (Fig. 19 e Fig. 20) have a negative fuel pressure (depression) at the burner inlet. They typically have the tank at a lower height than the burner.

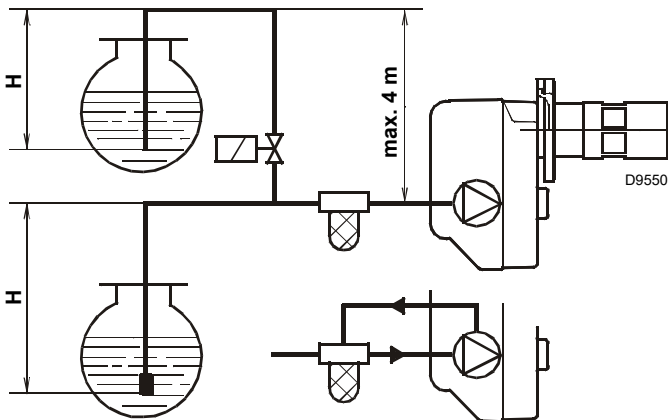

Fig. 19

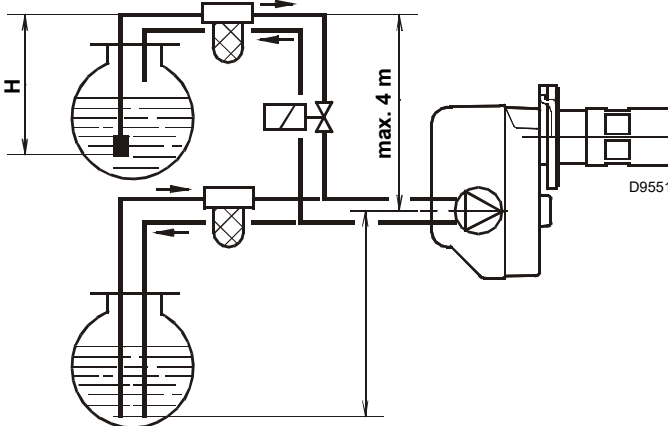

Fig. 20



The installer must ensure that the supply depression never exceeds 0.4 bar (30 cm Hg).

Beyond this limit, gas is released from the fuel.

Oil pipes must be completely airtight.

H metres	L metres	
	Øi 8 mm	Øi 10 mm
0	35	100
0.5	30	100
1	25	100
1.5	20	90
2	15	70
3	8	30
3.5	6	20

Tab. F

H = Difference in level

L = Max. length of the suction line

Ø = Internal pipe diameter

NOTE:

The shows the approximate maximum lengths for the supply line, depending on the height difference, length and diameter of the fuel line.

For use with fuels having more than 30% of biocomponent (FAME), in order to avoid over-oxygenation of the biodiesel, the manufacturer advises against two-pipe operation; if two-pipe operation is to be maintained, a degassing filter (1) should be used (Fig. 21).

Oxygenation of the biodiesel causes degradation of the fuel with the formation of potentially harmful compounds and deposits in the burner.

It is recommended to keep the tank clean and to replace the fuel if it remains in the tank for more than a year.

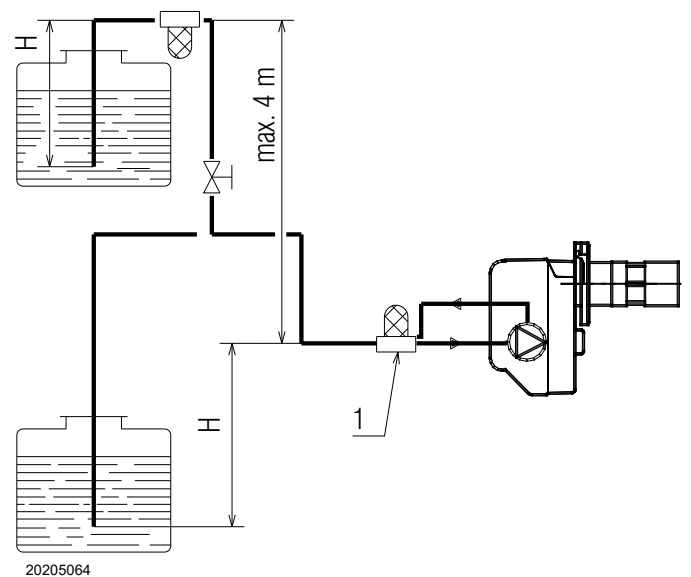

Fig. 21

6 Start-up, calibration and operation of the burner

6.1 Notes on safety for the first start-up



The first start-up of the burner must be carried out by qualified personnel, as indicated in this manual and in compliance with the standards and regulations of the laws in force.



Check the correct working of the adjustment, command and safety devices.

6.2 Combustion adjustment

In conformity with EN 267 standard, the application of the burner on the boiler, adjustment and testing must be carried out observing the instruction manual of the boiler, including verification of the CO and CO₂ concentration in the flue gases, their temperatures and the average temperature of the water in the boiler.



The combustion air is drawn in from outside, so there can be significant temperature variations that can affect the CO₂ percentage value.

It is recommended to adjust the CO₂ according to the graph shown.

E.g.: combustion air temperature of 20°C, adjust CO₂ to 12.5% (± 0.2%).

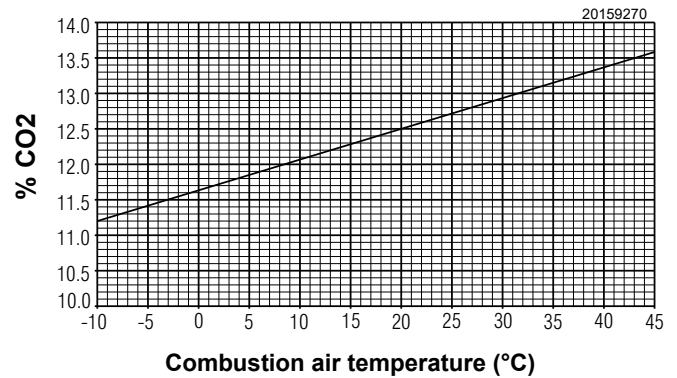

The values in Fig. 22 refer to 12.5% of CO₂ at sea level and with ambient and light oil temperature at 20°C.

Fig. 22

HEATING POWER

- Hi B10 - Light oil - HVO = 11.86 kWh/kg
- Hi B30 = 11.45 kWh/kg
- Hi B50 = 11.14 kWh/kg
- Hi B100 = 10.35 kWh/kg

B10 -- BGK1 -- Delavan

Nozzle		Pump pressure	Output	Head adjustment chamber	Adjustment air damper
GPH	Angle	bar	kg/h	Notch	Notch
0.40	60° W	13	1.5	1	1.4
0.50	60° W	12	1.7	1.5	1
0.60	60° W	12	2.1	2	2.2
0.65	60° W	12	2.3	2.5	2
0.75	60° W	12	2.7	3	3
0.75	60° W	14	3.0	3.5	3.2

Alternative nozzles: Danfoss H

B30 -- BGK1 -- Delavan

Nozzle		Pump pressure	Output	Head adjustment chamber	Adjustment air damper
GPH	Angle	bar	kg/h	Notch	Notch
0.40	60° W	14.0	1.53	0.0	5.00
0.50	60° W	12.0	1.84	0.5	1.00
0.55	60° W	12.0	1.95	0.75	1.50
0.60	60° W	12.0	2.10	0.9	1.75
0.65	60° W	12.0	2.34	1.0	2.00
0.75	60° W	12.0	2.72	1.5	2.50
0.75	60° W	14.0	2.90	2.0	2.75
0.85	60° W	12.0	3.18	2.5	3.00

B30 -- BGK1 -- Danfoss

Nozzle		Pump pressure	Output	Head adjustment chamber	Adjustment air damper
GPH	Angle	bar	kg/h	Notch	Notch
0.40	60° S	14.0	1.50	0.0	0.50
0.45	60° S	12.0	1.74	0.2	1.00
0.50	60° H	12.0	1.90	0.5	1.50
0.55	60° H	12.0	2.19	0.9	2.00
0.60	60° H	12.0	2.57	1.0	2.25
0.65	60° H	12.0	2.79	1.5	2.60
0.75	80° H	12.0	2.88	2.0	2.75
0.75	80° H	14.0	3.13	2.5	3.00
0.85	60° H	10.0	3.12	2.5	3.00

B50 -- BGK1 -- Delavan

Nozzle		Pump pressure	Output	Head adjustment chamber	Adjustment air damper
GPH	Angle	bar	kg/h	Notch	Notch
0.40	60° W	14.0	1.54	0.0	3.50
0.50	60° W	12.0	1.86	0.5	0.50
0.55	60° W	12.0	2.02	0.75	0.90
0.60	60° W	12.0	2.16	0.9	1.00
0.65	60° W	12.0	2.41	1	2.10
0.75	60° W	12.0	2.74	1.5	1.90
0.75	60° W	14.0	2.93	2.0	2.90
0.85	60° W	12.0	3.17	2.5	2.50

B50 -- BGK1 -- Danfoss

Nozzle		Pump pressure	Output	Head adjustment chamber	Adjustment air damper
GPH	Angle	bar	kg/h	Notch	Notch
0.40	60° S	14.0	1.50	0.0	0.50
0.45	60° S	12.0	1.75	0.2	1.00
0.50	60° H	12.0	1.87	0.5	1.25
0.55	60° H	12.0	2.18	0.9	1.50
0.60	60° H	12.0	2.60	1.0	2.25
0.65	60° H	12.0	2.87	1.5	2.50
0.75	80° H	12.0	2.93	2.0	2.75
0.75	80° H	14.0	3.16	2.5	2.50

B100 -- BGK1 -- Delavan

Nozzle		Pump pressure	Output	Head adjustment chamber	Adjustment air damper
GPH	Angle	bar	kg/h	Notch	Notch
0.40	60° W	14.0	1.64	0.0	0.00
0.50	60° W	12.0	1.98	0.5	0.80
0.55	80° W	12.0	2.03	1.5	0.20
0.60	60° W	12.0	2.21	1.5	0.50
0.65	60° W	12.0	2.47	1.0	1.90
0.75	60° W	12.0	2.90	1.5	2.50
0.75	60° W	14.0	3.11	2.0	3.00
0.85	60° W	13.0	3.41	2.5	3.10

B100 -- BGK1 -- Steinen

Nozzle		Pump pressure	Output	Head adjustment chamber	Adjustment air damper
GPH	Angle	bar	kg/h	Notch	Notch
0.40	80° HT	14.0	1.73	0.0	0.20
0.50	60° H	13.0	2.00	0.5	0.20
0.60	60° H	12.0	2.39	0.5	2.40
0.65	60° H	14.0	2.52	1.5	2.40
0.75	60° H	12.0	2.82	2.0	1.50
0.85	60° H	12.0	3.40	2.3	3.00

B100 -- BGK1 -- Danfoss

Nozzle		Pump pressure	Output	Head adjustment chamber	Adjustment air damper
GPH	Angle	bar	kg/h	Notch	Notch
0.40	60° S	14.0	1.65	0.0	1.00
0.45	60° S	12.0	1.8	0.2	1.20
0.50	60° H	12.0	1.93	0.5	1.25
0.55	60° H	12.0	2.25	0.9	1.50
0.60	60° H	12.0	2.65	1.0	1.25
0.65	60° H	12.0	2.79	1.5	1.90
0.75	80° H	12.0	3.12	2.0	2.10
0.75	80° H	14.0	3.34	2.0	3.10

B10 -- BGK2 -- Delavan

Nozzle		Pump pressure	Output	Head adjustment chamber	Adjustment air damper
GPH	Angle	bar	kg/h	Notch	Notch
0.75	60° W	12	2.7	1.5	1.2
0.85	60° W	12	3.0	1.5	1.8
1.00	60° W	12	3.7	2	2
1.10	60° W	12	4.1	2.5	2.2
1.25	60° W	12	4.6	3.5	2.8
1.25	60° W	14	5.0	4	3

Alternative nozzles: Danfoss H

B30 -- BGK2 -- Delavan

Nozzle		Pump pressure	Output	Head adjustment chamber	Adjustment air damper
GPH	Angle	bar	kg/h	Notch	Notch
0.75	60° W	12.0	2.81	1.0	1.00
0.85	60° W	12.0	3.25	1.5	1.50
1.00	60° W	12.0	3.61	2.0	1.50
1.10	70° W	12.0	4.18	2.5	2.20
1.25	60° W	12.0	4.77	3.5	2.20
1.25	60° W	12.0	4.94	4.0	2.20
1.35	60° W	12.5	5.12	4.0	2.90

B30 -- BGK2 -- Steinen

Nozzle		Pump pressure	Output	Head adjustment chamber	Adjustment air damper
GPH	Angle	bar	kg/h	Notch	Notch
0.75	60° H	12.0	2.83	1.0	1.20
0.85	60° H	12.0	3.23	1.5	1.20
1.00	60° H	12.0	3.51	2.0	1.50
1.10	60° H	12.0	4.01	2.5	1.90
1.25	60° H	12.0	4.74	3.5	2.00
1.25	60° H	14.0	5.02	4.0	2.50

Nozzle		Pump pressure	Output	Head adjustment chamber	Adjustment air damper
GPH	Angle	bar	kg/h	Notch	Notch
1.35	60° H	13.0	5.17	4.0	2.50

B50 -- BGK2 -- Delavan

Nozzle		Pump pressure	Output	Head adjustment chamber	Adjustment air damper
GPH	Angle	bar	kg/h	Notch	Notch
0.75	60° W	13.0	2.88	1.0	1.10
0.85	60° W	12.0	3.32	1.5	1.00
1.00	60° W	12.0	3.70	2.0	1.20
1.10	70° W	12.0	4.20	2.5	1.50
1.25	60° W	12.0	4.76	3.5	2.00
1.35	60° W	13.0	5.37	4.0	3.00

B50 -- BGK2 -- Steinen

Nozzle		Pump pressure	Output	Head adjustment chamber	Adjustment air damper
GPH	Angle	bar	kg/h	Notch	Notch
0.75	60° H	13.0	2.86	1.0	1.00
0.85	60° H	12.0	3.25	1.5	1.00
1.00	60° H	12.0	3.51	2.0	1.20
1.10	60° H	12.0	4.01	2.5	1.50
1.25	60° H	12.0	4.80	3.5	2.00
1.35	60° H	13.0	5.37	4.0	3.00

B100 -- BGK2 -- Delavan

Nozzle		Pump pressure	Output	Head adjustment chamber	Adjustment air damper
GPH	Angle	bar	kg/h	Notch	Notch
0.75	60° W	13.0	3.09	1.0	1.00
0.85	60° W	12.0	3.49	1.5	1.00
1.00	60° W	12.0	3.93	2.0	1.20
1.10	70° W	12.0	4.40	2.5	1.50
1.25	60° W	12.0	5.00	3.5	1.50
1.35	60° W	13.0	5.73	4.0	2.50

B100 -- BGK2 -- Steinen

Nozzle		Pump pressure	Output	Head adjustment chamber	Adjustment air damper
GPH	Angle	bar	kg/h	Notch	Notch
0.75	60° H	14.0	3.08	1.0	1.00
0.85	60° H	12.0	3.42	1.5	1.00
1.00	60° H	12.0	3.73	2.0	1.20
1.10	60° H	12.0	4.33	2.5	1.30
1.25	60° H	12.0	4.96	3.5	1.90
1.35	60° H	14.0	5.70	4.0	2.50

B10 -- BGK3 -- Danfoss

Nozzle		Pump pressure	Output	Head adjustment chamber	Adjustment air damper
GPH	Angle	bar	kg/h	Notch	Notch
1.00	60° H	12	3.8	1	1.5
1.10	60° H	12	4.3	1.5	2
1.25	60° H	12	4.9	2	3
1.35	60° H	12	5.2	2.5	3.5
1.50	60° H	12	6.0	4	5

Alternative nozzles: Steinen H

B30 -- BGK3 -- Delavan

Nozzle		Pump pressure	Output	Head adjustment chamber	Adjustment air damper
GPH	Angle	bar	kg/h	Notch	Notch
1.10	60° W	12.0	3.98	1.0	1.00
1.25	60° W	12.0	4.58	2.0	1.25
1.35	60° W	12.0	5.20	2.5	2.00
1.50	60° W	12.0	5.74	3.0	3.00
1.75	60° W	11.5	6.33	3.0	4.50

B30 -- BGK3 -- Danfoss

Nozzle		Pump pressure	Output	Head adjustment chamber	Adjustment air damper
GPH	Angle	bar	kg/h	Notch	Notch
1.00	60° H	12.0	3.87	0.5	1.00
1.10	60° H	12.0	4.50	1.5	1.25
1.25	60° H	12.0	5.07	2.0	2.00
1.35	60° H	12.0	5.52	2.5	2.75
1.50	60° H	12.0	6.30	3.0	4.50

B50 -- BGK3 -- Delavan

Nozzle		Pump pressure	Output	Head adjustment chamber	Adjustment air damper
GPH	Angle	bar	kg/h	Notch	Notch
1.10	60° W	12.0	4.10	1.0	1.00
1.25	60° W	12.0	4.68	2.0	1.25
1.35	60° W	12.0	5.24	2.5	2.00
1.50	60° W	12.0	5.77	3.0	3.00
1.75	60° W	12.0	6.48	3.0	3.00

B50 -- BGK3 -- Danfoss

Nozzle		Pump pressure	Output	Head adjustment chamber	Adjustment air damper
GPH	Angle	bar	kg/h	Notch	Notch
1.00	60° H	12.0	3.92	0.5	1.00
1.10	60° H	12.0	4.52	1.0	1.25
1.25	60° H	12.0	5.10	2.0	2.00
1.35	60° H	12.0	5.54	2.5	2.50
1.50	60° H	12.0	6.30	3.0	3.00
1.50	60° H	13.5	6.52	3.0	3.00

B100 -- BGK3 -- Delavan

Nozzle		Pump pressure	Output	Head adjustment chamber	Adjustment air damper
GPH	Angle	bar	kg/h	Notch	Notch
1.10	60° W	12.0	4.40	1.0	1.00
1.25	60° W	12.0	4.98	2.0	1.25
1.35	60° W	12.0	5.48	2.5	2.00
1.50	60° W	12.0	5.98	3.0	3.00
1.75	60° W	12.5	6.96	3.0	5.00

B100 -- BGK3 -- Danfoss

Nozzle		Pump pressure	Output	Head adjustment chamber	Adjustment air damper
GPH	Angle	bar	kg/h	Notch	Notch
1.00	60° H	13.0	4.25	0.5	1.00
1.10	60° H	12.0	4.60	1.5	1.25
1.25	60° H	12.0	5.18	2.0	2.00
1.35	60° H	12.0	5.67	2.5	2.75
1.50	60° H	12.0	6.44	3.0	4.00
1.65	60° H	13.0	6.96	3.0	5.00

Tab. G

6.3 Nozzles

In order to guarantee that emissions do not vary, recommended and/or alternative nozzles specified by the Manufacturer in the Instruction and warning booklet should be used.



ATTENTION

It is advisable to replace nozzles once a year during periodical maintenance.



ATTENTION

Empty cone nozzles were used to achieve CLASS 3 emissions (EN267:1999).



CAUTION

The use of nozzles other than those specified by the Manufacturer and inadequate regular maintenance may result into emission limits non-conforming to the values set forth by the regulations in force, and in extremely serious cases, into potential hazards to people and objects.

The manufacturing Company shall not be liable for any such damage arising from non-observance of the requirements contained in this manual.

6.4 Electric system

Notes on safety for the electrical wiring



- The electrical wiring must be carried out with the electrical supply disconnected.
- Electrical wiring must be made in accordance with the regulations currently in force in the country of destination and by qualified personnel. Refer to the wiring diagrams.
- The manufacturer declines all responsibility for modifications or connections different from those shown in the wiring diagrams.
- Do not invert the neutral with the phase in the electrical supply line.
- Check that the electrical supply of the burner corresponds to that shown on the identification label and in this manual.
- The burner has been type-approved for intermittent use.
In the event of continuous operation, a cycle arrest must be ensured within 24 hours with the use of a time switch positioned in series with the thermostatic line. Refer to the wiring diagrams.
- The electrical safety of the device is obtained only when it is correctly connected to an efficient earthing system, made according to current standards. It is necessary to check this fundamental safety requirement. In the event of doubt, have the electrical system checked by qualified personnel.
- The electrical system must be suitable for the maximum power absorption of the device, as indicated on the label and in the manual, checking in particular that the section of the cables is suitable for that level of power absorption.
- For the main power supply of the device from the electricity mains:
 - do not use adapters, multiple sockets or extensions;
 - use a multiple pole switch with at least a 3 mm gap between the contacts (overvoltage category III), as envisaged by the present safety standards.
- Do not touch the device with wet or damp body parts and/or in bare feet.
- Do not pull the electric cables.
- Check proper insertion of connection connectors according to the symbols shown on the bottom of the flame control box: make sure that the connectors are fully inserted by pushing them all the way in, each in its relevant position. All connectors must have the connection cables facing towards the inside of the burner (See Fig. 24).

Before carrying out any maintenance, cleaning or checking operations:



Disconnect the electrical supply from the burner by means of the system main switch.



Close the fuel shut-off valve.



Condensation, the formation of ice and the entry of water are prohibited!



After carrying out maintenance, cleaning or checking operations, reassemble the cover and all the safety and protection devices of the burner.

20187803

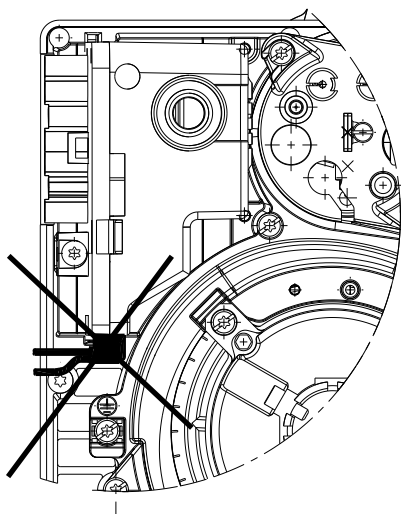

Fig. 23

20187802

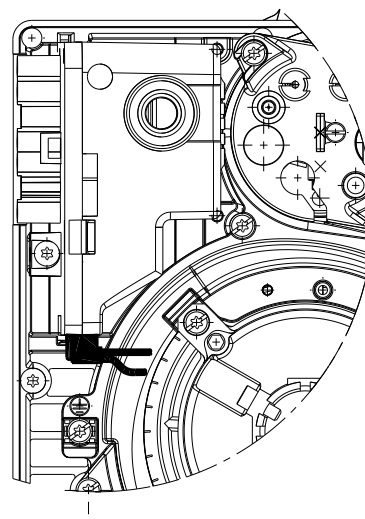

Fig. 24



Connectors inserted with the cables facing outwards the burner can damage the flame control equipment!



Insert connectors with the cables facing towards the inside of the burner.

6.5 Wiring diagram

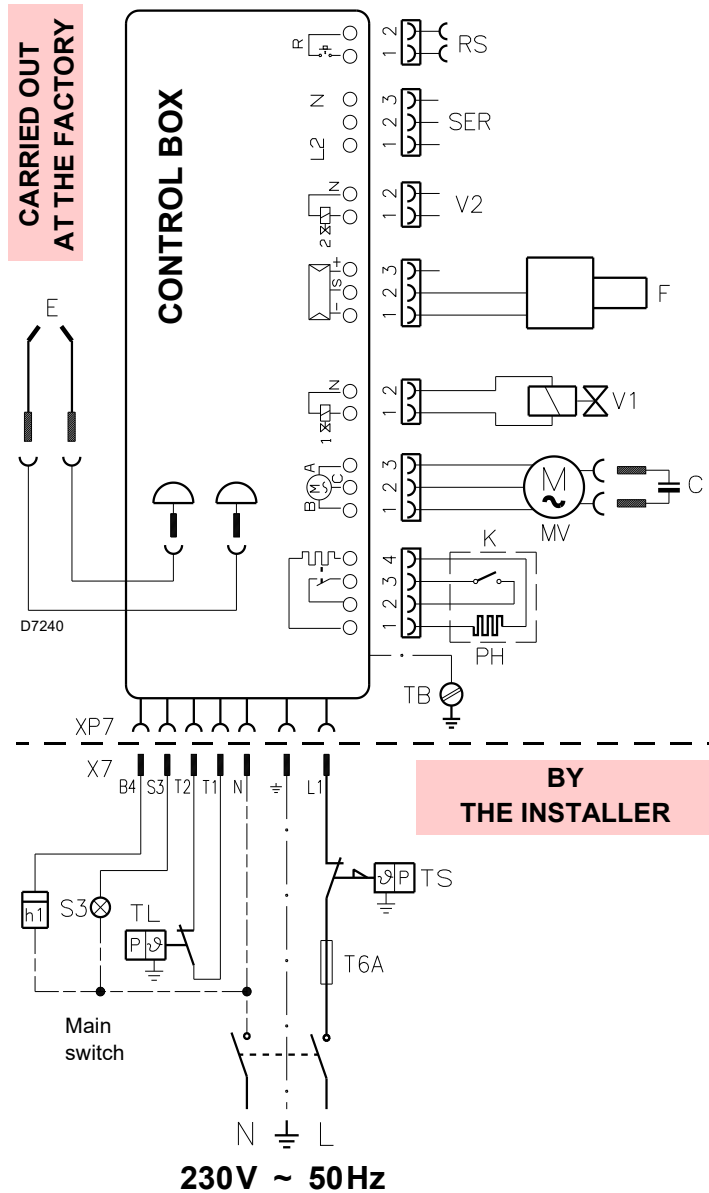

Fig. 25

KEY:

- C** – Motor capacitor
- E** – Electrode
- F** – Photodiode flame sensor
- h..** – Hour counter (230V ~ - 0.1A max.)
- K** – Start enable thermostat after pre-heating
- PH** – Fuel heater
- MV** – Fan motor
- RS** – Remote reset
- S3** – Remote lockout signal (230V ~ 0.5A max.)
- SER** – Safety lockout device
- T6A** – Fuse
- TB** – Burner earth
- TL** – Heat request thermostat
- TS** – Safety thermostat
- V1** – 1st stage valve
- V2** – Safety lockout device
- X..** – Plug
- XP..** – Socket



- Do not invert the neutral with the phase in the electrical supply line.
- Check that the electrical supply of the burner corresponds to that shown on the identification label and in this manual.
- The section of the conductors must be at least 1mm². (Unless requested otherwise by local standards and legislation).



Operate the burner by checking that it stops when opening the thermostats and that it locks out when engaging the flame sensor.



If the cover is still on, remove it and proceed with the electric wiring following the wiring diagrams. Use flexible cables in compliance with the EN 60 335-1 standard.



The burner can only be reset if power supply is applied to the control box.

6.6 Operating programme

Normal operation
POWER SUPPLY

20175092

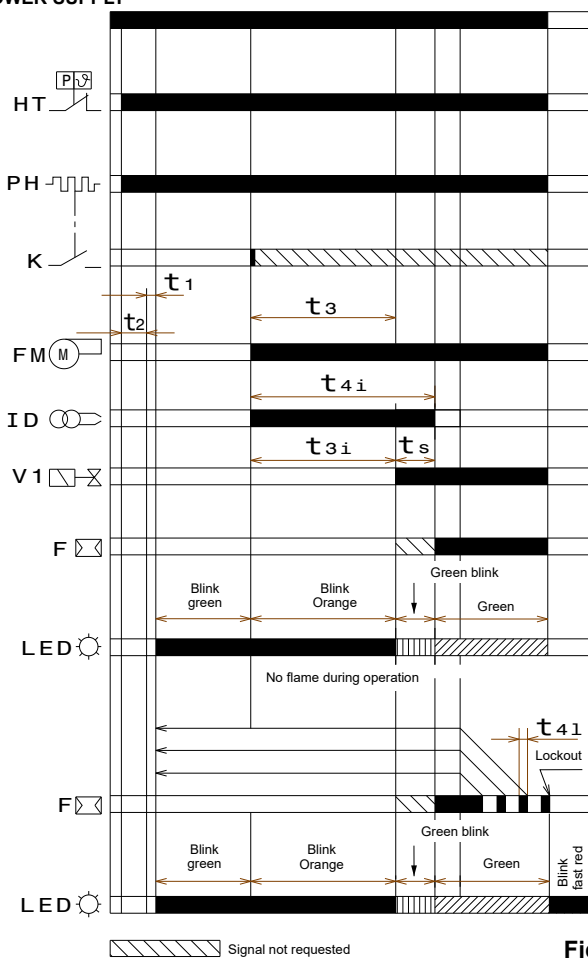

Fig. 26

Lockout due to extraneous light during pre-purging

POWER SUPPLY

20175093

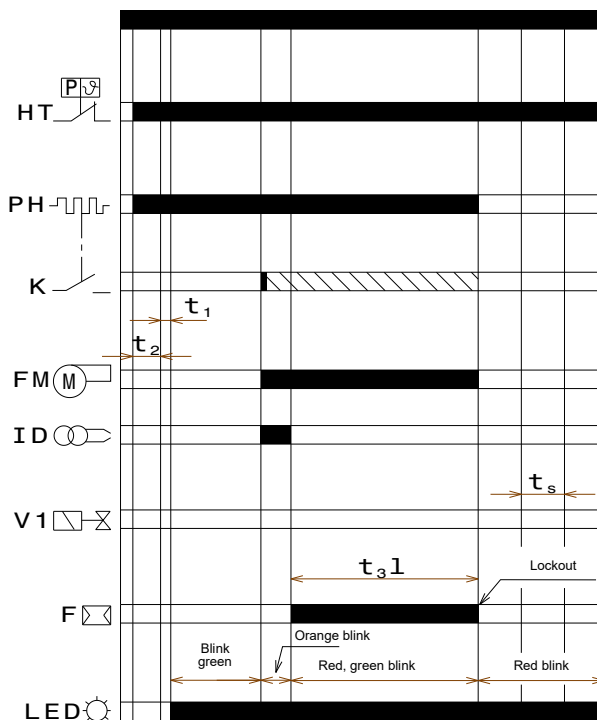

Fig. 28

Lockout due to ignition failure

POWER SUPPLY

20175094

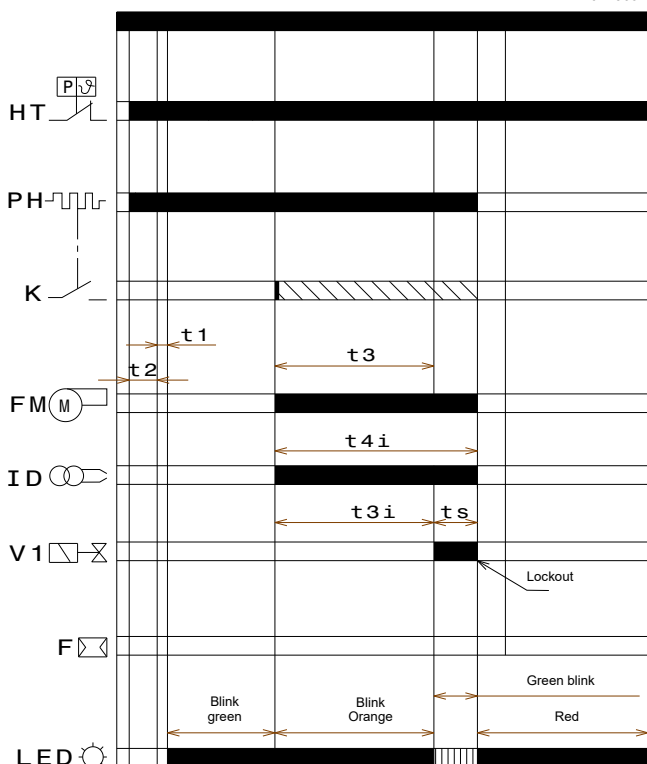

Fig. 27

Key

- F – Flame sensor
- FM – Fan motor
- HT – Heat request
- ID – Ignition device
- K – Start enable thermostat after pre-heating
- LED – LED colour inside the button
- PH – Fuel heater
- t1 – Standby time
- t2 – Initialisation checking time
- t3 – Pre-purging time
- t3i – Pre-ignition time
- t3l – Check for presence of extraneous light during pre-purging phase
- t4i – Total ignition time
- t4l – Reaction time to achieve safety lockout due to lack of flame
- ts – Safety time
- V1 – 1st stage valve

6.7 Table of times

Symbol	Description	Value (sec.)
t0	Stand-by: The burner waits for the heat request	-
t1	Standby time for an input signal: reaction time, control box remains in waiting mode for t1	2
t1l	Flame or flame simulation detected before demand for heat: the control box remains idle.	25
t2	Initialisation standby time: checking time following the main power start-up	< 4.5
t2l	Checks extraneous light or parasite flame during t2: waiting mode for t2l, then lockout: the motor does not start	25
t2p	Max. oil preheating time: waiting state for t2p, then the lockout takes place	max 600
t3	Pre-purging time: the fan motor is running, then the valve is activated	10
t3l	Checks extraneous light or parasite flame during pre-purging: control box goes into lockout at the end of t3l	25
t3i	Spark pre-ignition time	10
ts	Safety time	5
t4i	Total spark ignition time	15
t4l	Reaction time to achieve safety condition due to flame loss	< 1
-	Minimum time to reset the control box using reset button	0.4
-	Minimum time required to reset the control box using remote reset	0.8
tr	Re-cycles: max. 3 repeats of the complete start-up sequence in the case of flame loss during operation; the final action at the last attempt following flame failure is a lockout	3 re-cycles

Tab. H

6.7.1 Operation status indication

Status	Button colour button	Seconds		Colour code
Heat request standby	-	-	-	-
Standby for protection of ignition device	ORANGE Fast blinking	0.2	0.2	●○●○●○●○●○
Awaiting heat request with continuous purging	ORANGE Blink	0.5	2.5	●○●○●○●○●○
Fuel pre-heating time	GREEN Blink	0.5	2.5	■□■□■□■□■□
Pre-purging time and long pre-purging	ORANGE Blink	0.5	0.5	●○●○●○●○●○
Safety time without flame	GREEN Blink	0.5	0.5	■□■□■□■□■□
Safety time with flame	GREEN	-	-	■■■■■■■■■■■■■■■■
Normal operating position	GREEN	-	-	■■■■■■■■■■■■■■■■

Tab. I

Key

ON	OFF	Colour code
▲	△	RED
●	○	ORANGE
■	□	GREEN

Tab. J

6.7.2 Fault diagnostics - lockouts

Fault description	Button colour button	Seconds		Colour code
Extraneous light or false flame signal	GREEN, RED blinking alternately	0.5	0.5	■▲■▲■▲■▲■▲
Electrical power voltage fault	ORANGE slow blinking	2.5	2.5	●○●○●○●○●○
Electrical power frequency fault	ORANGE	-	-	●●●●●●●●●●
Flame control voltage fault	ORANGE, GREEN fast blinking alternately	0.2	0.2	●■●■●■●■●■
Reset or distance remote reset button fault	GREEN, RED fast blinking alternately	0.2	0.2	■▲■▲■▲■▲■▲
Lockout for no flame after Ts	RED	-	-	▲▲▲▲▲▲▲▲▲▲
Lockout for extraneous light signal or for parasite flame	RED blink	0.5	0.5	▲△▲△▲△▲△▲△
Lockout for maximum number of cycle repetitions (flame loss during operation)	RED Fast blinking	0.2	0.2	▲△▲△▲△▲△▲△
Lockout for fan motor error	RED, ORANGE blinking inverted	2.5	0.5	▲●▲●▲●▲●▲●
Lockout due to fault with the 1st stage valve control circuit	RED, GREEN blinking inverted	2.5	0.5	▲■▲■▲■▲■▲■
Lockout due to fault with the 2nd stage valve control circuit	RED blinking inverted	2.5	0.5	▲△▲△▲△▲△▲△
Lockout for max pre-heating time exceeded	RED blink	0.5	2.5	▲△▲△▲△▲△▲△
Lockout for eeprom error	ORANGE, GREEN blinking alternately	0.5	0.5	●■●■●■●■●■
1st stage valve lockout in short-circuit	RED, GREEN slow blinking	2.5	2.5	▲■▲■▲■▲■▲■

Tab. K

Key

ON	OFF	Colour code
▲	△	RED
●	○	ORANGE
■	□	GREEN

Tab. L

6.7.3 Fuel pre-heating function

The burner is provided with fuel preheating function. With an ignition request from the boiler heat request thermostat the burner remains in standby for the closing of the start-up thermostat (or preheating thermostat, K) positioned in correspondence of the nozzle holder.

If the start-up thermostat (or pre-heating thermostat, K) does not close after 600 seconds, the burner will reach the lockout condition.

If the flame goes out during operation, the burner carries out the recycle if the contact of the start-up thermostat (or the pre-heating one, K) is closed.

If the flame goes out during operation and the contact of the start-up thermostat (or the pre-heating one, K) is open, the burner purging continues for the post-purging time (if set), then the purging stops and the burner waits for the contact of the start-up thermostat (or the pre-heating one, K) to close before restarting the pre-purging time.

6.7.4 Switching off test

If the reset button or the remote reset is pressed during operation for more than 5 seconds and less than 10 seconds, (to avoid going to the next menu) the burner switches off, the oil valve closes, the flame goes out and the start-up sequence restarts.

If the switch off test is enabled, the number of repetitions of the start up sequence (see paragraph **“Recycle and limit of repetitions”** on page 33) and the number of possible resets (see paragraph **“Reset protection function”** on page 34), are reset.

6.7.5 Intermittent operation

After 24 hours of continuous operation, the control box starts the automatic switch-off sequence, followed by a restart, in order to check for a possible fault with the flame sensor. This automatic switch-off can be fixed at 1 hour, (see paragraph **“Programming menu”** on page 38).

The modification of the parameter setting for intermittent operation takes effect if:

- during the heat request, the switching off test function is enabled;
- there is a flame loss;
- the heat request switches off and then later restarts;
- the control box switches off and restarts;
- à the automatic restarting of the intermittent function occurs (1hour/24hours).

6.7.6 Recycle and limit of repetitions

The control box allows a recycle function, i.e. complete repetition of the start-up sequence, making up to 3 attempts, in the event of flame failure during operation.

If the flame fails 4 times during operation, this will cause the burner to lock out. If there is a new heat request during the recycle, the 3 attempts are reset when the limit thermostat (TL) switches.

After 510 seconds of continuous operation, a further possible attempt can be carried out (maximum 3).

When the power supply is disconnected or when there is a new heat request or after a reset or an automatic start-up (1 hour/24 hours), all possible restart attempts are reset (maximum 3).

6.7.7 Ignition device protection function

The flame control box ensures the protection of the integrated ignition device by preventing the start cycle (new ignition cycle) of the burner from occurring before a minimum time of 1 minute has elapsed between the end of one ignition spark and the next one.

- The protection function of the ignition device is indicated by the integrated reset button blinking fast in orange (0.2s ON - 0.2s OFF).
- The protection function of the ignition device is active if a new heat request or reset request occur within 1 minute after the end of the previous ignition.
- The protection function of the ignition device is not active at the first recycling due to flame failure, but after the second possible recycling, and only in this case, the inhibition time of the new ignition cycle is 90sec.
- The protection function of the ignition device is activated if continuous and intermittent heat requests are made during pre-purging.
- The protection function of the ignition device is deactivated if power supply is disconnected.
- Post-purging remains on during ignition protection function activation.

6.7.8 Presence of an extraneous light or parasite flame

The presence of a parasite flame or extraneous light can be detected in the stand-by state when the burner is stopped and waiting for a heat request during pre-heating.

If the presence of a flame or extraneous light is detected also in the "t2" stage, the motor does not start until the flame signal has disappeared or until lockout has been reached.

If after the fan motor starts, during pre-purging, an extraneous light or parasite flame is detected, the burner continues the purging until the light/flame goes off or reaches the lockout condition in 25 seconds.

If a parasite flame or extraneous light are detected during pre-purging, the ignition device stops, the pre-purging time is reset to zero and the time for checking the presence of the parasite flame or extraneous light starts (the motor continues to ventilate).

The function is cumulative and can be performed up to 2 times. If the parasite flame or extraneous light disappears before 25 seconds, the pre-purging time starts; if the parasite flame or extraneous light occurs again, the pre-purging time is reset to zero and the 25-second count for checking the presence of the parasite flame or extraneous light restarts.

When a parasite flame or extraneous light is detected for the third time, the burner locks out.

If, during missing flame recycling while operating and the consequent repetition of the start-up sequence, a parasite flame or extraneous light is detected, the 25 seconds control countdown starts (for checking for the presence of the parasite flame or the extraneous light).

The fault is indicated by the blinking LED (see paragraph "Fault diagnostics - lockouts" on page 33).

6.7.9 Pre-ignition phase of ignition transformer spark

During the pre-ignition phase, the integrated ignition device starts when the fan motor starts.

The spark ignition is present during all safety time.



ATTENTION

In the event of continuous recycling or heat requests that are close together, the maximum allowed number of cycle repetitions for the ignition transformer is one every minute.

6.7.10 Integrated reset button and remote burner reset

The burner can only be reset if power supply is applied to the control box.

The burner can be released by pressing, for at least 0.4 seconds, the reset button integrated in the control box and the unlocking occurs only when the button is released.

The burner can also be reset by pressing an external button (remote reset) connected to the burner for at least 0.8 seconds.



ATTENTION

If the reset button is pressed for more than 5 seconds, the control box will not be reset.

6.7.11 Reset protection function

The burner can be reset only 5 times consecutively, then power supply has to be disconnected for a new 5 reset possibilities.

6.7.12 Reset button/remote reset fault

If the reset button or the remote reset breaks or is kept pressed for more than 60 seconds, the fault is indicated by the blinking of the LED (see paragraph "Fault diagnostics - lockouts" on page 33) as long as the fault is present.

- This fault is only displayed and the led stops blinking when the fault disappears.
- If the fault is detected during pre-purging, preheating or safety time, the burner does not stop and the start-up sequence continues.
- If the fault is detected during operation, the burner does not stop.
- If the fault is detected during a lockout, the fault is not signalled and the burner cannot be reset.

6.7.13 External lockout signal (S3)

The burner is equipped with an external locking signal function, i.e. to signal (together with the integrated reset button) a burner locking alarm. The control box provides a command of an external lamp using the S3 output (230Vac-0.5Amp max).

6.7.14 Hour counter function (B4)

The burner has an hour counter function for the duration of the opening of the 1st stage valve and therefore for fuel consumption. The control box provides control of an external hour counter through the Hour-Counter output (230V AC-0.1Amp max.) of the control box connected to pin B4 of the 7 pole socket coming from the boiler power supply connection at the burner.

6.7.15 Monitoring the power supply voltage

The control box automatically measures the mains voltage.

If the voltage is less than 170V or more than 280V, the burner stops, interrupts the operating cycle and remains in stand-by, signalling a fault. The fault is indicated by the blinking LED (see paragraph “**Fault diagnostics - lockouts**” on page 33).

The burner restarts when the voltage exceeds approx. 180V or if it goes below 270V.

- If the fault is detected with flame operation, the valve is immediately closed and the motor stops.
- If the anomaly is detected during pre-purging, the motor stops.
- If the mains voltage stays within the intermediate values (170÷180V or 270÷280V) when the main power supply switch is closed or after a power failure, the burner does not start.
- If the burner is in lockout, the mains voltage is monitored but not signalled as there is a lockout signal and cannot be reset.

During the ignition time the mains voltage monitoring is deactivated.

6.7.16 Frequency supply error

The control box automatically detects the value of the frequency of the main supply in the range of 50 - 60 Hz, in both cases working times are verified. The fault is indicated by the blinking LED (see paragraph “**Fault diagnostics - lockouts**” on page 33).

- If the fault is detected before heat request the burner does not start.
- If the fault is detected during the pre-purging, the burner remains in purge condition and the fault is appropriately signalled.
- The fault is not detected during normal running, the burner remains in this state.

When the fault disappears, the burner restarts.

6.7.17 Internal voltage anomaly

The control box automatically detects if the internal voltage works correctly. The fault is indicated by the blinking LED (see paragraph “**Fault diagnostics - lockouts**” on page 33).

- If the anomaly is detected during the initialisation check time, the burner does not start.
- If the anomaly is detected after a lockout the burner does not start.
- If the anomaly is detected after a shut-down test, the burner does not start.
- The fault is not detected during normal running, the burner remains in this state.

When the fault disappears, the burner restarts.

6.7.18 Checking the fan motor

The control box automatically detects the presence of the fan motor and, if disconnected, it performs a lockout. The lockout is indicated by the blinking of the LED (see paragraph “**Fault diagnostics - lockouts**” on page 33).

6.7.19 Checking the internal electronic control circuit of the 1st stage valve

The control box detects the presence of a fault at the 1st stage valve control electronic circuit, the fault is indicated by the blinking LED (see paragraph “**Fault diagnostics - lockouts**” on page 33):

- if the anomaly is detected during the initialisation, the burner goes into lockout.
- if the anomaly is detected during the pre-purging, the burner goes into lockout.
- During a recycling, if the fault is detected, the burner does not start and goes into lockout.
- The fault is not detected during normal flame operation, the burner remains in this state.
- The fault is not detected if the burner is in lockout.

6.7.20 Checking the internal electronic control circuit of the 2nd stage valve(*)

The control box detects the presence of a fault at the 2nd stage valve control electronic circuit, the fault is indicated by the blinking of the LED (see paragraph “**Fault diagnostics - lockouts**” on page 33):

- if the anomaly is detected during the initialisation, the burner goes into lockout.
- if the anomaly is detected during pre-purging, the burner goes into lockout.
- During a recycling, if the fault is detected, the burner does not start and goes into lockout.
- If the fault is detected when the motor activation command and valve 1 command are present, the burner locks out.
- The fault is not detected if the burner is in lockout.

(*) The 2nd stage control function is reserved and not used.

6.7.21 Checking the 1st stage valve short circuit

The control box not only detects the presence of a fault in the electronic control circuit of the 1st stage valve, but it is also able to detect the presence of the short circuit of the valve itself. In this case the control box sets to lockout mode to protect against overcurrent. This lockout can occur with valve operating correctly even if the internal electrical branch connected to the valve is damaged due to a fault.

The fault is indicated by the blinking of LEDs.

6.7.22 EEprom check

The control box automatically detects if EEprom memory of micro-controller has failed and will perform a lockout. The lockout is indicated by the blinking of the LED (see paragraph “**Fault diagnostics - lockouts**” on page 33).

6.7.23 Post-purging

Post-purging is a function that allows you to maintain the air purging even after the burner is switched off in the absence of the heat request for a pre-set time.

The burner switches off the flame when the heat request thermostat opens, cutting off the fuel supply to the valves.

The post-purging function is not performed:

- after a motor or valve lock-out (only for control box internal faults);
- if the heat request is interrupted during pre-purging.

Post-purging occurs:

- if the heat request is interrupted during the safety time.
- If the heat request is interrupted during normal operation.
- After a lockout due to parasite flame in pre-purging.

- After a lockout due to lack of flame at the end of Ts.
- After a lockout due to no more recycles allowed for flame going off.
- After a 1st stage valve lockout in short-circuit.

NOTE:

If during post-purging there is an extraneous light or a parasite flame, the burner goes into lockout after 25 seconds and post-purging is not stopped.

If during post-purging there is a new heat request, the post-purging time is halted, the fan motor stops and a new burner operating cycle starts.

6.7.24 Continuous purging

Continuous purging is a function that maintains the air ventilation independently of the request for burner ignition.

From the moment when it is set, the motor remains in operation both when the heat request thermostat (TL) is not switched over (burner switched off), and when the burner is in lockout.

With the switching of the heat request thermostat (TL), the motor stops for the standby time of 2 seconds and a new burner operation cycle is started.

- If during continuous purging when there is no heat request a parasite flame is detected, the motor stays on and a fault is signalled. The burner reaches the lockout condition after 25 seconds.
- If during continuous purging a parasite flame is detected, the motor stays on but if a heat request occurs the motor is switched off, the motor is not started after the standby (2sec) if the parasite flame persists; the burner reaches the lockout condition after 25 seconds.
After the lockout has been reset the motor is restarted.
- The motor stays on even in a lockout.
- Continuous purging is interrupted if an internal fault is detected that brings the burner to the lockout condition (EEPROM, motor, 1st stage valve).

6.7.25 Lockout log

The control box allows the logging of the type and number of lockouts that have occurred and keeps them even without the electrical power supply.

The log of the lockouts allows you to display the last 10 lockouts (see paragraph “Programming menu” on page 38).

Once the programming menu page has been reached by pressing the reset button the last lockout is displayed, pressing 10 times displays the least recent lockout (each time the burner reaches the lockout condition the oldest one is removed).

5 seconds after the last pressing of the buttons, the type of lockout is displayed, see paragraph “Fault diagnostics - lockouts” on page 33).

6.7.26 Logging of burner operating parameters

The control box allows you to log the operating time of the opening of the 1st stage valve.

That way, you can determine how much fuel has been consumed during operation.

The frequency of the count is 1 second. Saving to memory (eeprom) of the data occurs every 30 minutes if the burner is on. Saving to memory is carried out even if in the previous 30 minutes the control box was operating only for a short period of time.

If the control box is cut off from the mains power supply between one saving and the next (after 30 minutes) the information about this interval is lost.

If in the interval between one saving and the next a lockout is set, there is writing to memory that involves also the logging of the operating hours.

Together with the operating hours also the number of the burner's 1st stage valve openings is saved.

In the menu (see paragraph “Programming menu” on page 38) it is possible to independently reset both the operating hour meter and the meter for the number of openings of the 1st stage valve that occurred.

- The number of openings of the 1st stage valve is a maximum of: 16.777.215 (after which it is reset).
- The meter for the number of openings of the first stage valve is a maximum: 65,535 days (after which it is reset).

6.7.27 Admissible lengths of the external connections to the burner

Outlet cables of the burner	Identification 7-pin plug	Maximum length allowed (metres)
Mains electric power supply	L1 (L), N	20
Heat request thermostat	TL (T1,T2)	20
Hour counter	B4	3
External lockout indicator	S3	20
Remote reset	R (RS)	20

Tab. M



ATTENTION

In the event of burner applications with remote controls greater than those indicated in Tab. M, insert the relay control devices (230Vac) with contacts placed near or far not more than the maximum indicated lengths.

6.7.28 Long pre-purging

If a long pre-purging is enabled, an initial pre-purging of 1 min and 50 sec beyond the default pre-purging time (10 sec) is carried out.

In recycles due to flame loss when operating, the long pre-purging is not carried out but only the pre-purging with the default time (10 sec).

6.8 Fuel pre-heating automatic deactivation

In automatic mode, the pre-heating function can be deactivated by pressing the distance remote reset button (external).

Preheating disabling sequence	Button Led colour
Deactivate pre-heating only if there is no lockout or fault condition	-
Deactivate pre-heating using the distance remote reset button.	-
Supply the burner and simultaneously keep the distance remote reset button pressed for 3 seconds.	RED
Release the distance remote reset button within 3 seconds.	OFF
The burner will start deactivating preheating only if the distance remote reset button is released within 3 seconds.	-

Tab. N

Pre-heating remains off until:

- a lockout condition occurs;
- a main power supply failure occurs;
- a stop for intermittent operation occurs.

The pre-heating deactivation function is not lost if the shut-down test is enabled or if the heat demand thermostat is opened as well as in case of recycling due to flame loss during operation.

6.9 Programming menu

6.9.1 General notes

The programming menu can be accessed via the integrated reset button, or by remote reset during OPERATION and in STANDBY. If in the menu page the reset or remote reset button is not pressed within 10 seconds, the page will be automatically exited and there will be a green LED blinking for the time set.

If the number of presses on the reset or remote reset button exceeds the maximum allowable, the value that stays in memory will be the maximum one.

If the reset or remote reset button is pressed for more than 60 seconds a button error will be displayed.

6.9.2 Block diagram for entering the menu

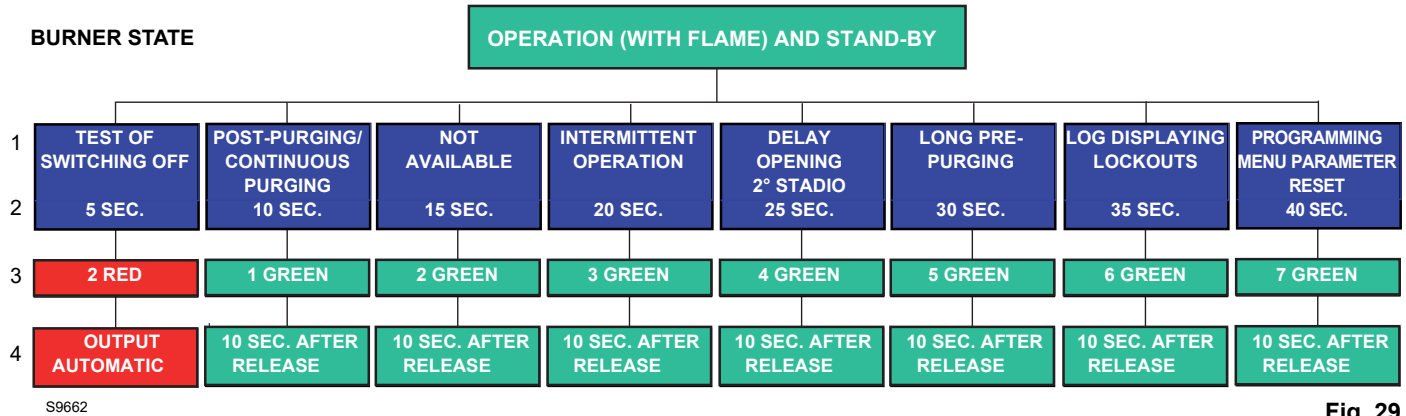

Fig. 29

Function	Button release time	No. of blinks of the LED for menu page	No. of times the reset button is pressed	No. of blinks of the LED (green)	Quitting the menu
Test of Switching off	5s ≤ t < 10s	2 blinks RED	/ none	/ none	Automatic starting from the end of the blink
Post-purging/ Continuous purging	10s ≤ t < 15s	1 GREEN blink	1 = 1 minute 2 = 2 minutes 3 = 3 minutes 4 = 4 minutes 5 = 5 minutes 6 = 6 minutes 7 = continuous purging 8 = 0 m (deactivated) (default)	1 blink 2 blinks 3 blinks 4 blinks 5 blinks 6 blinks 7 blinks 8 blinks	10 sec. after the release of the button
Not available	15s ≤ t < 20s	2 blinks GREEN	/	/	/
Operation intermittent	20s ≤ t < 25s	3 blinks GREEN	1 = 1 hour 2 = 24 hours (default)	1 blink 2 blinks	10 sec. after button release
Opening delay 2nd stage (*)	25s ≤ t < 30s	4 blinks GREEN	1 = 8 sec 2 = 20 sec (default) 3 = 35 sec	1 blink 2 blinks 3 blinks	10 seconds after button release
Pre-purging long	30s ≤ t < 35s	5 blinks GREEN	1 = activated 2 = deactivated (default)	1 blink 2 blinks	10 sec. after button release
Display lockout log	35s ≤ t < 40s	6 blinks GREEN	1 = last lockout 2 = 9th lockout 3 = 8th lockout 4 = 7th lockout 5 = 6th lockout 6 = 5th lockout 7 = 4th lockout 8 = 3rd lockout 9 = 2nd lockout 10 = less recent lockout	Displaying the type of lockout according to Tab. K	10 sec after the release of the button (if at level 1). When at level 2, 10 sec after the display of the type of lockout or else pressing the button again before 10 sec you return to level 1 from where, 10 seconds after nothing has been done to the buttons, you exit the menu
Parameter reset programming menu	40s ≤ t < 45s	7 blinks GREEN	1 = reset of the lockout log 2 = reset of the no. of lockouts 3 = reset of operating hours 4 = reset of the no. of heat requests 5 = reset of the default values of the menu parameters	/	10 sec. after button release

(*) The 2nd stage valve control function is reserved and not used.

Tab. O

6.9.3 Switching off test

Sequence for shut-down test programming

- Programming allowed in OPERATING mode and in STAND-BY.
- Press the button for 5 sec. $\leq t < 10$ sec.
- The RED LED blinks twice (0.2 sec. ON; 0.2 sec. OFF).
- Release the button.
- The burner will begin a shutdown, followed by a restart.

After shut-down, the burner restarts automatically and the no. of attempts of recycle is restored.

At the exit of shut-down test page menu there are no blinking led.

6.9.4 Post-purging and continuous purging

The post-purging time can be set for a maximum of **6 minutes**, proceeding as follows:

Programming sequence

- Programming allowed in OPERATING mode and in STAND-BY
- Press the button for 10 sec. $\leq t < 15$ sec.
- GREEN led blinking 1 time
- Release the button.
- GREEN led OFF
- Press the button 1 to 6 times (*) = 1 to 6 minutes
7 times = continuous purging
- GREEN led ON and OFF at each pressure and release
- After 10 sec., the GREEN LED will blink for the number of times programmed (0.5 sec. ON; 0.5 sec. OFF)

Disabling sequence

- Reset allowed in OPERATING mode and in STAND-BY.
- Press the button for 10 sec. $\leq t < 15$ sec.
- GREEN led blinking 1 time
- Release the button.
- GREEN led OFF
- Press the button 8 times (*)
- GREEN led ON and OFF at each pressure and release
- After 10 sec. the GREEN led blinks for 8 times (0.5s ON; 0.5s OFF)

If heat request stops during programming of post-purging function, the exit menu occurs without saving the setting value.

If heat request stops during the led blinking occur exit menu, but the setting value is stored.

6.9.5 Intermittent operation

Sequence for enable/disable

- Programming allowed in OPERATING mode and in STAND-BY.
- Press the button for 20 sec. $\leq t < 25$ sec.
- GREEN led blinking 3 times
- Release the button.
- GREEN led OFF
- Press the button once to enable a shut-down every hour (*)
- Press the button 2 times to enable a shut-down every hour 24 hours (*)
- GREEN led ON and OFF at each pressure and release
- After 10 sec., the GREEN LED will blink for the number of times programmed (0.5 sec. ON; 0.5 sec. OFF).

The modification of the parameter setting for Intermittent operation takes effect:

- after the next heat request by the thermostat (HT)
- after the activation of a switch-off test
- after flame disappearance during operation
- after disconnecting and reconnecting the electrical supply

6.9.6 Setting the 2nd stage opening delay

The 2nd stage valve control function is reserved and not used.

6.9.7 Setting a long pre-purging

The control box allows you to set the long pre-purging, see paragraph “**Block diagram for entering the menu**” on page 38.

Sequence for setting a long pre-purging

- Programming allowed in OPERATING mode and in STAND-BY
- Press the button for 30 sec. $\leq t < 35$ sec.
- GREEN led blinking 5 times
- Release the button.
- GREEN led OFF
- Press the button once to enable the long pre-purging (*)
- Press the button twice to disable the long pre-purging (*)
- GREEN led ON and OFF at each pressure and release
- After 10 sec., the GREEN LED will blink for the number of times programmed (0.5 sec. ON; 0.5 sec. OFF).

6.9.8 Displaying the lockout log

The control box allows you to display the last 10 lockouts that occurred and were logged, accessing the Programming menu. Access to this page is possible both in STAND-BY, as well as in the OPERATING status.

Display sequence of the last lockout that occurred

- Keep the button pressed for 35 sec. = $t < 40$ sec.
- GREEN led blinking 6 times
- Release the button.
- Display of the type of lockout stored for 10 sec.

The time displaying the type of lockout can be extended by repressing the reset button during the display of the lockout (the lockout display continues for another 10s).



ATTENTION

(*) Always wait for 1 second after pressing and releasing the button to ensure the command is logged correctly.

6.9.9 Resetting the programming menu parameters and the lockout log

The control box allows you to reset the log and the number of lockouts, the operating hours, the number of ignitions and to recover the menu default parameter values, see paragraph “**Block diagram for entering the menu**” on page 38.

Sequence for setting and restoring the parameters

- Programming allowed in OPERATING mode and in STAND-BY.
- Press the button for 40 sec. $\leq t < 45$ sec.
- The GREEN led blinks 7 times.
- Release the button.
- GREEN led OFF
- Press the button once to reset the lockout log (*)
- Press the button twice to reset the number of lockouts (*)
- Press the button 3 times to reset the number of hours operating with flame (*)

- Press the button 4 times to reset the number of heat requests (*)
- Press the button 5 times to reset all the default values of the parameters of the PROGRAMMING MENU (*)
- GREEN led ON and OFF at each pressure and release
- After 10 sec., the GREEN LED will blink for the number of times programmed (0.5 sec. ON; 0.5 sec. OFF).



ATTENTION

(*) **Always wait for 1 second after pressing and releasing the button to ensure the command is logged correctly.**

6.10 Lockout types

Whenever a lockout occurs, the control box shows the reasons for the fault (and the reasons can be identified by the reset button colour). The sequence of pulses issued by the control box of the

LED in the reset button identifies the possible types of fault, which are listed in the table below:

Lockout description	Lockout time	LED colour (1)	Probable cause
Presence of extraneous light at motor start	After 25 seconds	▲▲▲▲	– presence of a false flame after heat request.
Pre-heating not completed	After 600 seconds	▲▲▲▲	– fuel heater resistance fault – start-up thermostat fault
Detection of extraneous light during pre-purging, post-purging or pre-heating	After 25 seconds	▲▲▲▲	– presence of false flame signal during pre-purging, post-purging or pre-heating
The flame is not detected after the safety time	After 5 seconds from the activation of the oil valve	RED Always ON	– flame sensor faulty or dirty – oil valve faulty or dirty – faulty ignition transformer – badly regulated burner – fuel oil not present
Flame failure during operation	After 3 recycles	▲▲▲▲	– burner not calibrated correctly – oil valve faulty or dirty – flame sensor faulty or dirty
Fan motor error	Immediate	▲●▲●	– faulty fan motor – fan motor not connected
Fault of the oil valve control circuit	Immediate	▲■▲■	– oil valve faulty – oil valve control circuit faulty
Eeprom error	Immediate	●■●■	– faulty internal memory

Tab. P

(1) For the blinking frequency of the reset button see "Fault diagnostics - lockouts" on page 33.



ATTENTION

To reset the control box after visual diagnostics have been displayed, you must press the reset button.



ATTENTION

In the event the burner stops, in order to prevent any damage to the installation, do not unblock the burner more than twice in a row. If the burner locks out for a third time, contact the customer service.



DANGER

In the event there are further lockouts or faults with the burner, the maintenance interventions must only be carried out by qualified, authorised personnel, in accordance with the contents of this manual and in compliance with the standards and regulations of current laws.

7 Maintenance

7.1 Notes on safety for the maintenance

The periodic maintenance is essential for the good operation, safety, yield and duration of the burner.

It allows you to reduce consumption and polluting emissions and to keep the product in a reliable state over time.



The maintenance interventions and the calibration of the burner must only be carried out by qualified, authorised personnel, in accordance with the contents of this manual and in compliance with the standards and regulations of current laws.

Before carrying out any maintenance, cleaning or checking operations:



disconnect the electrical supply from the burner by means of the system main switch;



close the fuel shut-off valve.



Wait for the components in contact with heat sources to cool down completely.

7.2 Maintenance programme

7.2.1 Maintenance frequency



The combustion system should be checked at least once a year by a representative of the Manufacturer or another specialised technician.

7.2.2 Checking and cleaning



The operator must use the required equipment during maintenance.

Pump

If the pressure is unstable, or the pump runs noisily, the flexible hose must be detached from the line filter and the fuel must be sucked from a tank located near the burner.

This measure permits the cause of the anomaly to be traced to either the suction piping or the pump.

If the problem lies in the suction line, check the filter is clean and that air is not entering the piping.

Flexible hoses

Check there are no occlusions or obstructions in the fuel supply or return lines, in the air suction areas, and in the combustion product waste pipe.

Filters

Clean the fuel suction line filter and pump filter.

If rust or other impurities are observed inside the pump, use a separate pump to lift any water and other impurities that may have deposited on the bottom of the tank.

Electrical connections

Check that burner electrical connections are carried out correctly (page 30).

Fan

Check to make sure that no dust has accumulated inside the fan or on its impellers, as this condition will cause a reduction in the air flow rate and provoke polluting combustion. If necessary, clean the fan.

Combustion head

Check to make sure that all the parts of the combustion head are in good condition, positioned correctly, free of all impurities, and that no deformation has been caused by operation at high temperatures.

Clean the combustion head in the fuel outlet area.

Check that the positioning of the combustion head is correct and that it is properly fixed to the boiler.

Nozzles

Do not clean the nozzle openings.

It is advisable to replace nozzles during periodical maintenance, or when necessary.

The change of the nozzle requires a combustion control.

Electrodes

Check the correct positioning of the electrodes (page 18).

Diffuser assembly

Clean, using compressed air, the diffuser assembly located inside the combustion head assembly.

Collar seal

Replace the collar seal in case of wear or tear.

Combustion

Carry out an analysis of the combustion flue gases. Significant differences with respect to the previous measurements indicate the points where most care should be exercised during maintenance.

Let the burner run at full power for about ten minutes, correctly calibrating all the components indicated in this manual. **Then carry out a combustion check by verifying:**

- Flue gas opacity index (Bacharach);
- CO₂ percentage(%);
- CO content (ppm);
- NO_x content (ppm);
- Flue gas temperature at the flue.

8 Faults / Solutions

Below are the causes and possible solutions to some problems that may cause the burner starting failure or malfunction.

A fault normally triggers the LED lockout signal in the reset button of the control box.

When lockout lamp lights up the burner will start working only after pushing the reset button. If ignition is then normal, the lockout can be attributed to a temporary and non-hazardous fault.

However, if lockout continues, you must determine the cause of the problem and take the actions illustrated in Tab. Q.

Faults	Fault Diagnostics	Probable cause	Solutions
The burner does not start with the heat request.	-	Lack of electrical supply.	Check for voltage in L, N and plug. Check the conditions of the fuses. Check that safety thermostat is not in lockout.
	■▲■▲	The flame sensor detects an extraneous light.	Eliminate the extraneous light.
	-	The connections of the control box are not plugged in correctly.	Check and connect all plugs and sockets correctly.
	▲△▲△	The heater is faulty.	Replace.
The burner locks out before or during pre-purging or post-purging.	▲△▲△	The flame sensor detects an extraneous light.	Eliminate the extraneous light.
Burner runs normally in pre-purging and ignition cycle but locks out after approx. 5 seconds.	RED Always ON	The flame sensor is dirty.	Clean it.
		The flame sensor is faulty.	Replace it.
		The flame comes off or does not form.	Check fuel pressure and flow rate.
			Check the air flow.
Burner starts with an ignition delay.	-	The ignition electrodes are wrongly positioned.	Adjust them according to the instructions in this manual.
		Air output is too high.	Set the air output according to the instructions of this manual.
		Dirty or damaged nozzle.	Replace it.

Tab. Q



ATTENTION Any contractual and extra-contractual liability of the manufacturer is excluded for damage caused to persons, animals and property by wrong installation and calibration of the burner, by its improper, incorrect and unreasonable use, by failure to comply with the instruction manual supplied with the burner and by the intervention of unauthorised personnel.

9 Appendix - Accessories**Light oil filter kit**

Burner	Filtering level (μm)	Code
All models	60	3006561

Line filter kit

Burner	Filtering level (μm)	Code
All models	100	3000926

7-pin plug kit

Burner	Code
All models	3000945

RIELLO

RIELLO S.p.A.
I-37045 Legnago (VR)
Tel.: +39.0442.630111
[http:// www.riello.it](http://www.riello.it)
[http:// www.riello.com](http://www.riello.com)